

---

---

---

**GARDNER DENVER®**

3-1-529  
7<sup>TH</sup> EDITION  
JUNE 2008

**TRIPLEX PISTON PUMP**

**5" STROKE**

**MODEL  
TEE**

**PARTS LIST**

**Gardner**  

---

**Denver**

## **MAINTAIN PUMP RELIABILITY AND PERFORMANCE WITH GENUINE GARDNER DENVER® PARTS AND SUPPORT SERVICES**

Gardner Denver® genuine pump parts are manufactured to design tolerances and are developed for optimum dependability. Design and material innovations are the result of years of experience with hundreds of different pump applications. Reliability in materials and quality assurance are incorporated in our genuine replacement parts.

**Your authorized Gardner Denver distributor offers all the backup you'll need.** A worldwide network of authorized distributors provides the finest product support in the pump industry. Your local authorized distributor maintains a large inventory of genuine parts and he is backed up for emergency parts issues with access to Oklahoma City, OK. and the factory in Quincy, IL.

Your authorized distributor can support all your Gardner Denver pump needs.

Trained parts specialists are available to assist you in selecting the correct replacement parts.

**ALL ORDERS for PARTS should be placed with the NEAREST Authorized Distributor.**

To find your nearest distributor you may use one of the following choices:

\* Log onto the Gardner Denver web site: [www.gardnerdenver.com](http://www.gardnerdenver.com)

\* Send an E-Mail request to: [pumps@gardnerdenver.com](mailto:pumps@gardnerdenver.com)

\* Contact one of our sales offices listed below.

**The Gardner Denver Sales Offices are located as follows:**

### **DOMESTIC**

Gardner Denver  
2200 South Prospect  
Oklahoma City, OK. 73129

Phone: (405) 677-5736

Fax: (405) 677-5807

### **INTERNATIONAL**

Gardner Denver  
1800 Gardner Expressway  
Quincy, IL 62301

Phone: (217) 222-5400

Fax: (217) 223-1581

### **INSTRUCTIONS FOR ORDERING REPAIR PARTS:**

When ordering parts, specify Pump MODEL and SERIAL NUMBER (see nameplate on unit). The Serial Number is also stamped on top of the frame at the connecting end. (Between the cradle opening and the fluid cylinder)

**SPECIFY THE NUMBER OF PARTS REQUIRED, EXACTLY.**

**DO NOT ORDER BY SETS OR GROUPS.**

To determine the Right Hand and Left-Hand side of a pump, stand at the power end and look toward the fluid end. Right Hand and Left Hand are indicated in parenthesis following the part name, i.e. (RH) and (LH), when appropriate.

**For Operating and Service Instructions see:**

**SERVICE MANUAL 3-1-606**

## TABLE OF CONTENTS

Maintain Pump Reliability And Performance with Genuine Gardner Denver Parts and Support Services .....	i
Instructions For Ordering Repair Parts .....	i
Table of Contents .....	ii
Frame Group .....	1
Eccentric, Shaft and Bearing Group .....	2
Oil Circulating Pump .....	3
Oil Filter .....	4
Connecting Rod .....	5
Crosshead & Oil Stop Head Group .....	6
Oil Pump and Piping .....	7 & 8
Crosshead Lubrication Piping - LEFT HAND DRIVE .....	9
Crosshead Lubrication Piping - RIGHT HAND DRIVE .....	10
Fluid End - Low Pressure Cast Aluminum Bronze Cylinder (4 x 5) .....	11
Fluid End - Medium Pressure Cast Aluminum Bronze Cylinder (3 x 5) .....	12
Fluid End - High Pressure Block Steel Cylinder (2 x 5) .....	13
Fluid End - High Pressure Block Steel Cylinder (4 x 5) .....	14
Fluid End - High Pressure Cast Steel Cylinder (3 x 5) .....	15
Stuffing Box, Plunger and Packing .....	16 thru 25
Piston and Liners .....	26
Delrin Disc Fluid Valves for Low Pressure Cast Aluminum Bronze Cylinder (4 x 5) .....	27
Wing Guided Fluid Valves Low Pressure Cast Aluminum Bronze Cylinder (4 x 5) .....	28
Delrin Disc Fluid Valves for Medium Pressure Cast Aluminum Bronze Cyl (3 x 5) .....	29
Wing Guided Fluid Valves Medium Pressure Cast Aluminum Bronze Cyl (3 x 5) .....	30
Delrin Disc Suction Fluid Valves for High Pressure Block Steel Cylinder (2 x 5) .....	31
Delrin Disc Discharge Fluid Valves for High Pressure Block Steel Cylinder (2 x 5) .....	32
Wing Guided S&D Fluid Valves for High Pressure Block Steel Cylinder (2 x 5) .....	33 thru 36
Wing Guided S&D Fluid Valves for High Pressure Block Steel Cylinder (4 x 5) .....	37 thru 40
Stem Guided S&D Fluid Valves, Stainless Steel, Abrasion Resistant for High Pressure Block Steel Cylinder (4 x 5) .....	41
Wing Guided S&D Fluid Valves for High Pressure Cast Steel Cylinder (3 x 5) .....	42 thru 44
Stem Guided S&D Fluid Valves, SS, Abrasion Resistant for High Pressure Cast Steel Cylinder (3 x 5) ....	45
Lubricator Group (Optional Equipment) .....	46
Piston Rod Wash Piping (Optional Equipment) .....	47 & 48
Valve Seat Puller (Optional Equipment) .....	49
Customer Repair Information .....	50
Customer NOTES .....	51
Gardner Denver Unit Record .....	Inside Back Cover

Order by Part Number and Description. Reference Numbers are shown for your convenience only.

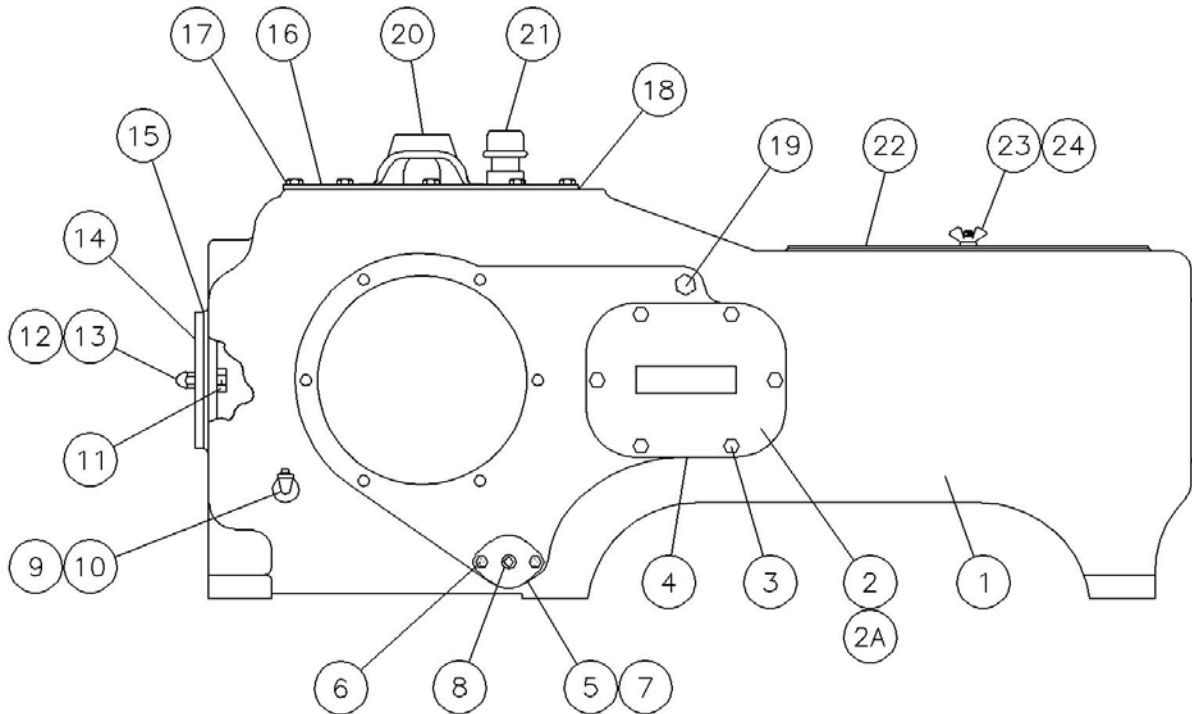

Ref. Drawing - 301TEE810

**FRAME GROUP**

Ref. No.	Description	Qty.	Part No.
1	FRAME (POWER END) .....	1	304TEE001
2	INSPECTION PLATE, With Oil Manifold (Crosshead).....	1	301TEE052
2A	INSPECTION PLATE (Crosshead) .....	1	302TEE052
3	SCREW, Inspection Plate .....	12	75A136
4	GASKET, Inspection Plate .....	2	25C1941
5	GASKET, Crankcase Flange.....	2	25C157N
6	SCREW, Crankcase Flange.....	4	655ED030
7	FLANGE, Crankcase Oil Drain.....	2	29AUX27
8	PLUG, Crankcase Flange .....	2	64AA7
9	PLUG, Oil Level.....	2	64AA5
10	PIPE ELBOW, Oil Level .....	1	64D2
11	RETAINER PLATE (Includes next item) .....	1	PE1400
	STUD .....	3	79A69
12	NUT-ACORN.....	3	50Q14
13	GASKET- COPPER, Retainer Stud Nut.....	3	25F44
14	INSPECTION PLATE (Frame End).....	1	200TEE052
15	GASKET (Frame End Inspection Plate).....	1	200TEE715
16	HOOD.....	1	201TEE053
17	SCREW, Hood .....	12	75A136
18	GASKET, Hood .....	1	201TEE715
19	PLUG (OPPOSITE SIDE) .....	1	64B3
20	LIFTING EYE .....	2	200TEE263
21	BREATHER.....	1	5C7
22	INSPECTION PLATE (CRADLE COVER) *.....	1	201TEE052
23	STUD .....	2	79A466
24	WING NUT .....	2	50H1

\* See page 50 for all cradle cover options.

Order by Part Number and Description. Reference Numbers are shown for your convenience only.

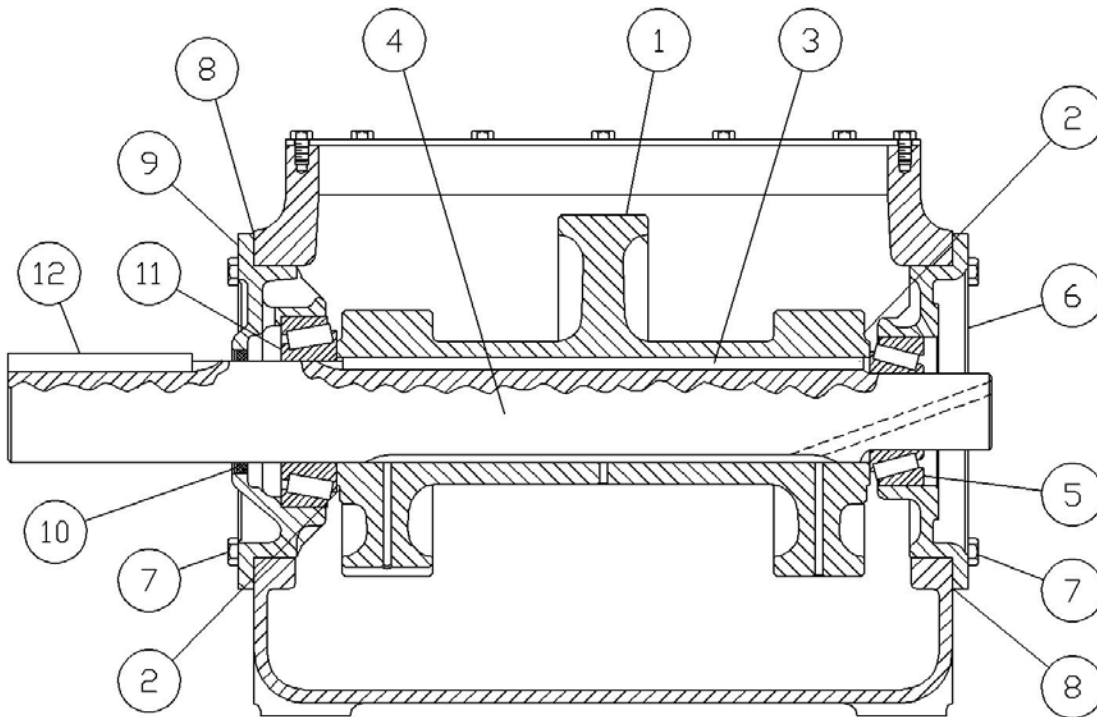

Ref Drawing - 313TEE799

### ECCENTRIC, SHAFT & BEARING GROUP

Ref No.	Description	Qty.	Part No.
1	ECCENTRIC, Includes the next item .....	1	200TEE255
2	ORIFICE .....	2	200TEE814
3	KEY, Eccentric to Shaft .....	1	35K17
4	SHAFT-ECCENTRIC .....	1	1PE367
5	BEARING, Eccentric Shaft .....	1	12C60
6	HOUSING-BEARING, Oil Pump End .....	1	2PE266
7	SCREW, Bearing Housing to Frame .....	12	655EF050
8	GASKET, Bearing Housing .....	2	25C1945
9	HOUSING-BEARING, Drive End .....	1	3PE366
10	SEAL-OIL, Eccentric Shaft .....	1	60G63
11	BEARING, Eccentric Shaft .....	1	12BA64
12	KEY, Drive .....	1	35B72

Order by Part Number and Description. Reference Numbers are shown for your convenience only.

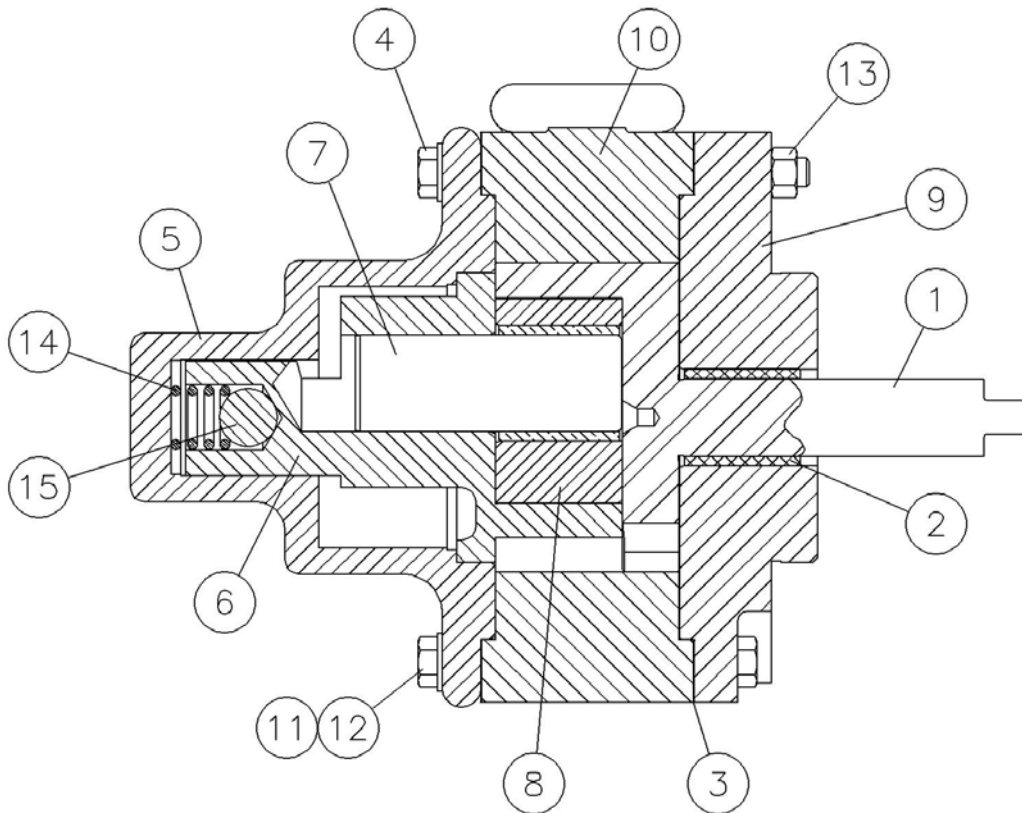

Ref. Drawing – 311TEE799

### OIL CIRCULATING PUMP

Ref No.	Description	Qty.	Part No.
	OIL CIRCULATING PUMP, Includes Ref No's 1 thru 10	1	200PEE188
1	ROTOR .....	1	2109376
2	BUSHING, Bracket.....	1	2118594
3	GASKET, Cover .....	2	54C222
4	SCREW, Cover Cap.....	8	2118595
5	COVER.....	1	2109371
6	IDLER CARRIER ASSEMBLY, Includes Ref No's 7.....	1	2109372
7	PIN, Idler .....	1	2109373
8	GEAR, Idler .....	1	2118596
9	BRACKET ASSEMBLY, Includes Ref No. 2 .....	1	2109370
10	HOUSING.....	1	2118597
11	SCREW, Housing.....	4	2118598
12	SCREW, Housing.....	4	2118599
13	NUT, Housing screw .....	4	2118600
14	SPRING, Ball.....	1	2118601
15	BALL.....	1	2118602

The Part Numbers that are listed are for those parts that are provided for repair.

Order by Part Number and Description. Reference Numbers are shown for your convenience only.

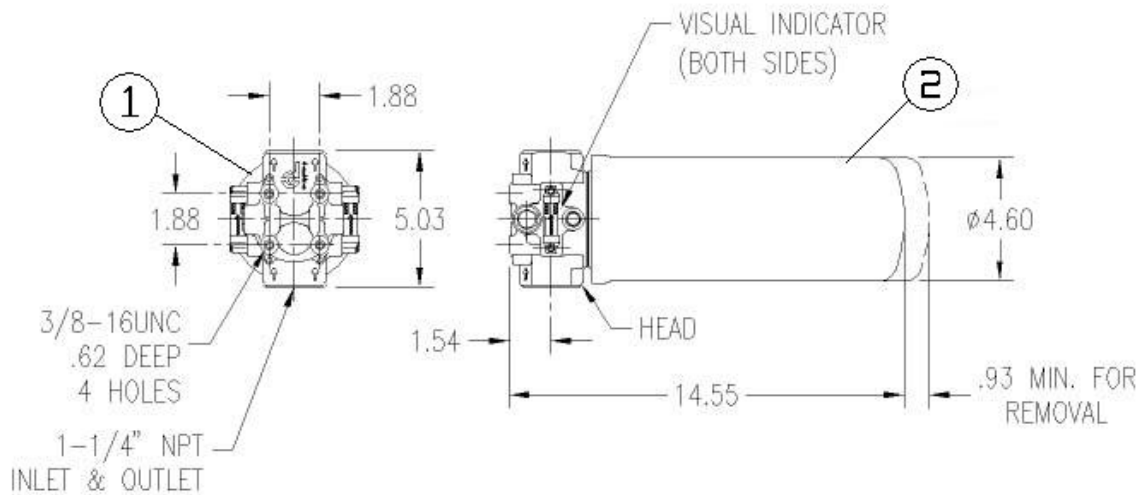

### OIL FILTER

Ref No.	Description	Qty.	Part No.
	OIL FILTER ASSEMBLY, Includes next 2 items	1	26C51
1	HEAD ASSEMBLY .....	1	2118128
2	ELEMENT .....	1	2118384

Order by Part Number and Description. Reference Numbers are shown for your convenience only.

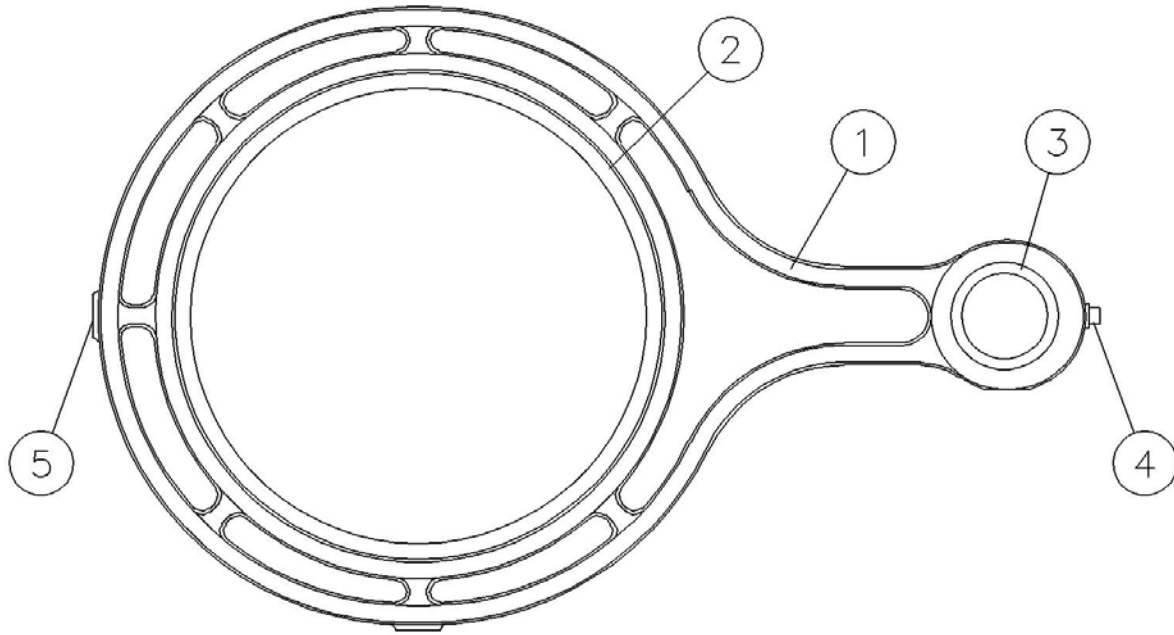

Ref. Drawing – 302TEE810

### CONNECTING ROD

Ref. No.	Description	Qty.	Part No.
1	CONNECTING ROD, Includes the next 4 items .....	3	PE417
2	BUSHING, Eccentric .....	3	PE421
3	BUSHING, Crosshead Pin .....	3	PE229
4	PLUG.....	3	64AC2
5	LOCK SCREW .....	3	75LM162N

Order by Part Number and Description. Reference Numbers are shown for your convenience only.

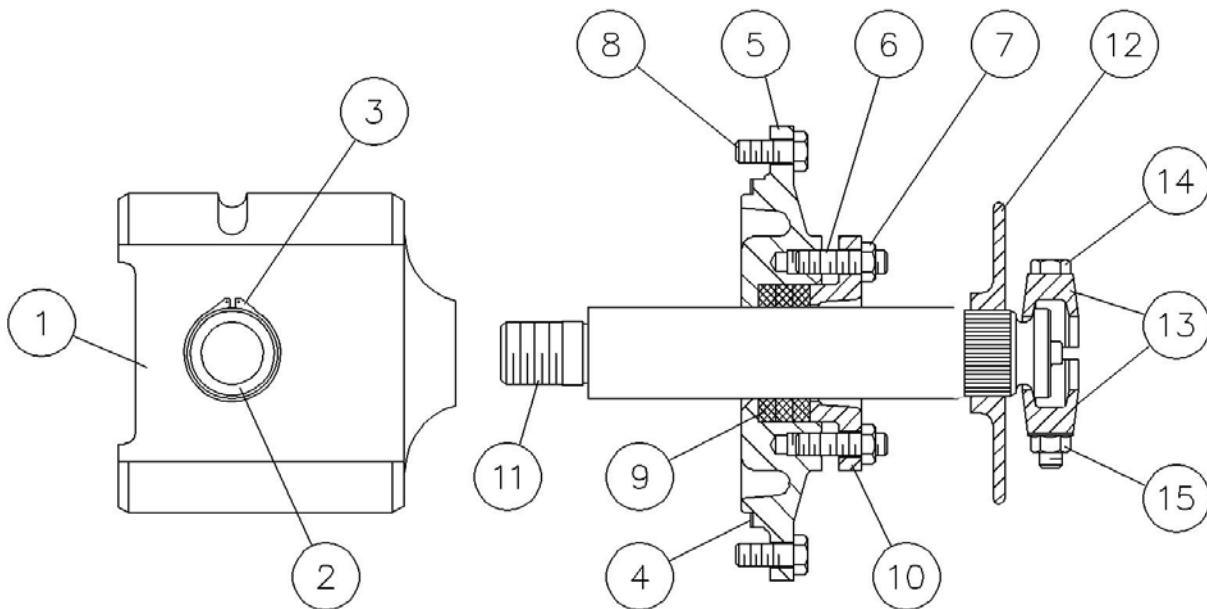

Ref. Drawing - 300TEE810

### CROSSHEAD & OIL STOP HEAD GROUP

Ref No.	Description	Qty.	Part No.
1	CROSSHEAD (Standard Size) .....	3	300TEE005
	CROSSHEAD (0.125" Oversized – Optional) *** .....	3	301TEE005
2	CROSSHEAD PIN.....	3	2005051
3	RING, Crosshead Pin Retainer.....	6	65W19
4	GASKET, Oil Stop Head to Frame.....	3	25C1948
	OIL STOP HEAD ASSEMBLY, Includes Ref No's 5, 6 & 7 .....	3	PE226A
5	OIL STOP HEAD.....	3	PE226
6	STUD, Gland.....	6	79A238
7	NUT, Gland .....	6	50F5
8	SCREW, Oil Stop Head to Frame .....	12	655EE050
9	PACKING, Oil Stop Head.....	3	60DD99
10	GLAND, Oil Stop Head .....	3	PE238
11	ROD-EXTENSION .....	3	300TEE839
12	BAFFLE, Piston Rod ** .....	3	200TAE840
13	PLUNGER COUPLING ASSEMBLY, Includes Ref No's 14 & 15.....	3	201TAE092A
14	SCREW, Coupling.....	6	655EE17S
15	NUT, Coupling.....	6	50AW35

\* See Note Number 1, page 50, for customer repair information

\*\* See Note Number 2, page 50, for customer repair information

\*\*\* See Note Number 3, page 50, for customer repair information

# OIL PUMP AND PIPING

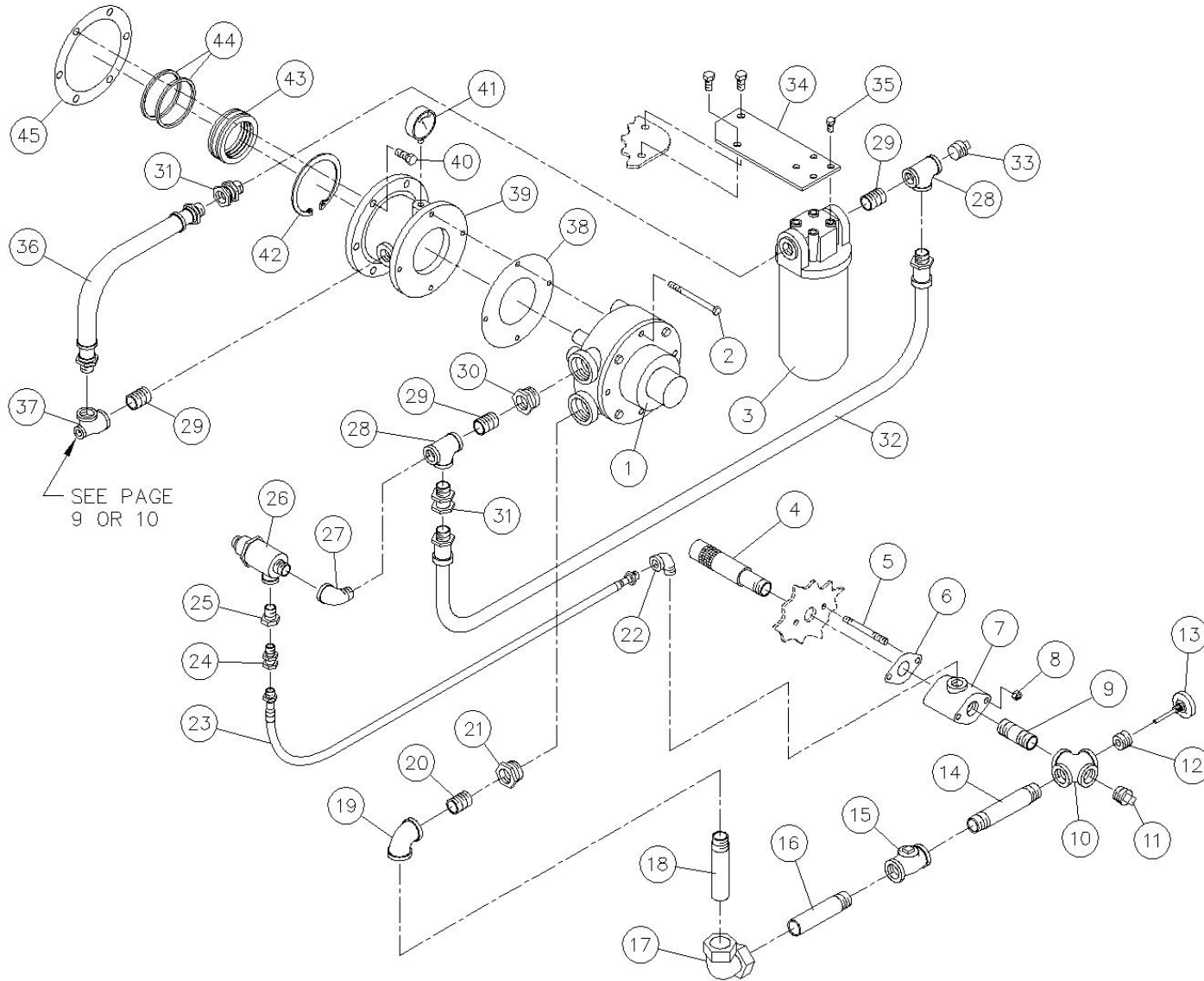

Order by Part Number and Description. Reference Numbers are shown for your convenience only.

**OIL PUMP AND PIPING**

Ref. No.	Name of Part	Qty.	Part No.	Ref. No.	Name of Part	Qty.	Part No.
1	* OIL PUMP (Includes next item)	1	200PEE188	24	HOSE ADAPTOR	1	29Q6
2	SCREW, Oil Pump to Adaptor	4	655ED190	25	PIPE BUSHING	1	64E95
3	** OIL FILTER	1	26C51	26	LIQUID RELIEF VALVE	1	90Q22
4	OIL SCREEN	1	2WAJ511	27	PIPE STREET ELBOW	1	64D6
5	STUD, Connector to Frame	2	79A204	28	PIPE TEE	2	64G7
6	GASKET, Oil Drain Flange	1	25C157N	29	PIPE NIPPLE	3	63U12X14
7	CONNECTOR	1	200PEE284	30	PIPE BUSHING	1	64E6
8	NUT, Connector to Frame Stud	2	50B3	31	HOSE ADAPTOR	2	29Q16
9	PIPE NIPPLE	1	64H4	32	HOSE ASSEMBLY	1	29R26
10	PIPE CROSS	1	64K18	33	PIPE PLUG	1	64A24
11	PIPE PLUG	1	64A25	34	FILTER BRACKET	1	200TEE389
12	BUSHING	1	64E15	35	SCREW, Filter to Bracket	4	75LM51
13	GAUGE	1	27H11	36	HOSE ASSEMBLY	1	29E12
14	PIPE NIPPLE	1	64H4	37	PIPE TEE	1	64P78
15	CHECK VALVE	1	300TEE308	38	GASKET, Oil Pump to Adaptor	1	201PEE715
16	PIPE NIPPLE	1	304TEE126	39	ADAPTOR, Oil Pump	1	200PEE170
17	COUPLING	1	300TEE572	40	SCREW, Adaptor to Bearing Housing	6	655EE050
18	PIPE NIPPLE	1	303TEE126	41	PRESSURE GAUGE	1	27A13
20	PIPE NIPPLE	1	63H29	43	OIL SEAL, Main Shaft	1	1PE447
21	PIPE BUSHING	1	64E7	44	PISTON RING, Oil Seal	2	65A33
22	PIPE STREET ELBOW	1	64D5	45	SHIM	2	77G16
23	HOSE ASSEMBLY	1	29430				

\* For Oil Pump and Component Parts – See Page 3

\*\* For Oil Filter and Component Parts – See Page 4

Order by Part Number and Description. Reference Numbers are shown for your convenience only.

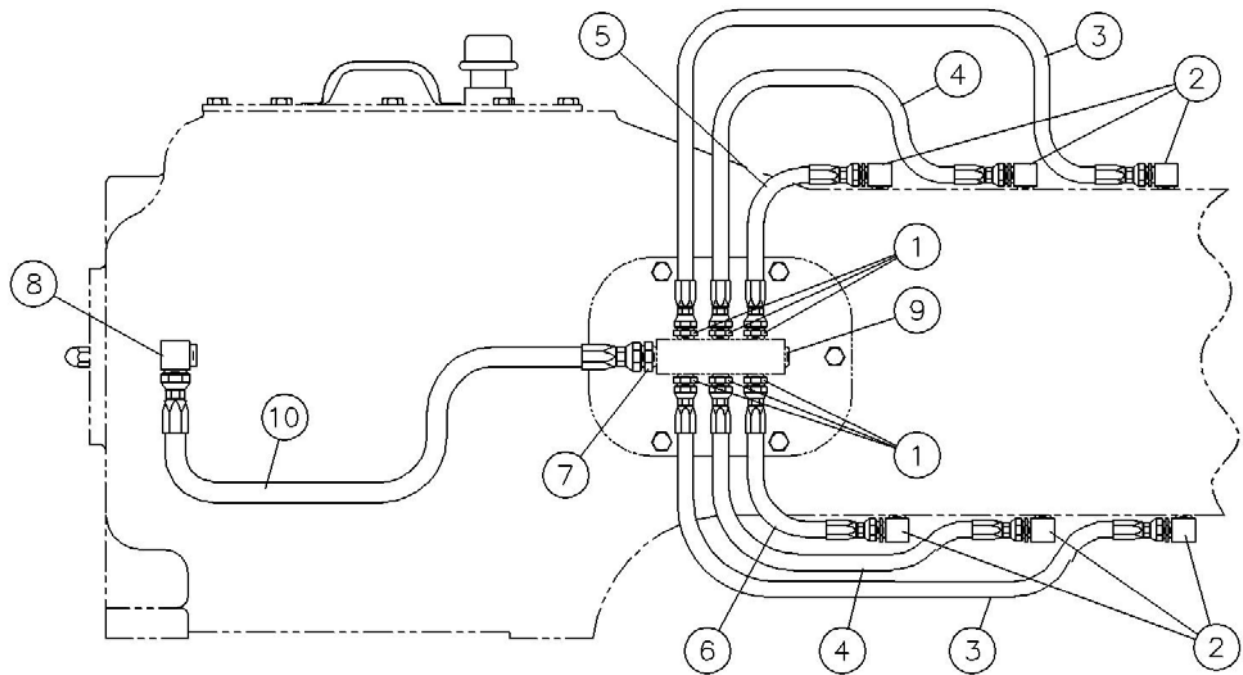

Ref. Drawing - 323TEE810

**LEFT HAND DRIVE - CROSSHEAD LUBRICATION PIPING**

Ref No.	Description	Qty.	Part No.
1	ADAPTOR .....	6	29Z207
2	ADAPTOR .....	6	29Z242
3	HOSE ASSEMBLY .....	2	1000T29
4	HOSE ASSEMBLY .....	2	301TEE127
5	HOSE ASSEMBLY .....	1	1000T09
6	HOSE ASSEMBLY .....	1	30031008
7	ADAPTOR .....	1	29Z224
8	ADAPTOR .....	1	142635
9	PLUG.....	1	64B3
10	HOSE ASSEMBLY .....	1	1001T55

Order by Part Number and Description. Reference Numbers are shown for your convenience only.

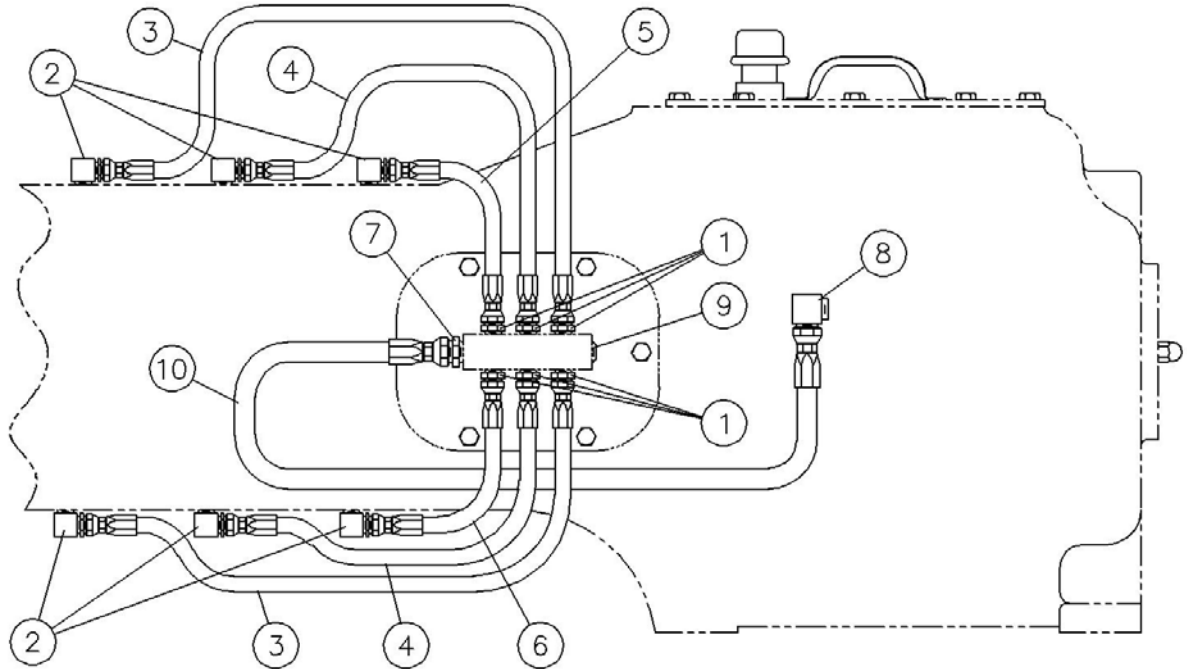

Ref. Drawing - 324TEE810

### RIGHT HAND DRIVE - CROSSHEAD LUBRICATION PIPING

Ref No.	Description	Qty.	Part No.
1	ADAPTOR .....	6	29Z207
2	ADAPTOR .....	6	29Z242
3	HOSE ASSEMBLY .....	2	1000T29
4	HOSE ASSEMBLY .....	2	301TEE127
5	HOSE ASSEMBLY .....	1	1000T09
6	HOSE ASSEMBLY .....	1	30031008
7	ADAPTOR .....	1	29Z224
8	ADAPTOR .....	1	142635
9	PLUG.....	1	64B3
10	HOSE ASSEMBLY .....	1	1001T55

Order by Part Number and Description. Reference Numbers are shown for your convenience only.

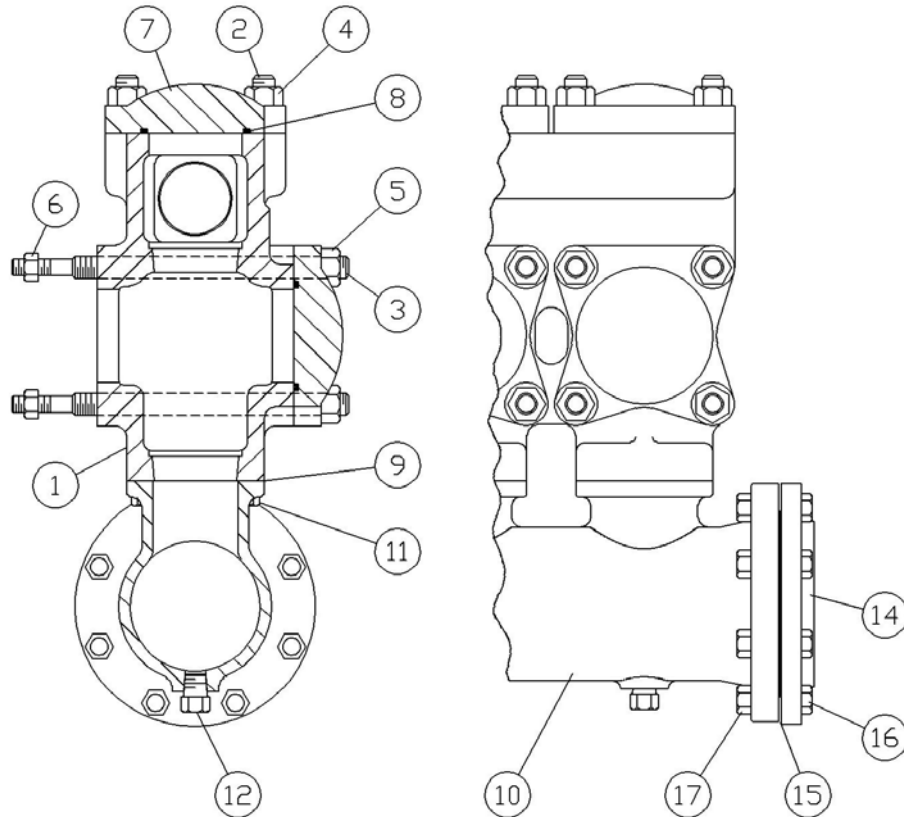

Ref. Drawing – 314TEE799

**FLUID END (TEEA) (4x5)**  
**Low Pressure Cast Aluminum Bronze Cylinder – 4”**

Ref No.	Description	Qty.	Part No.
	FLUID CYLINDER ASSEMBLY, Includes Ref No's: 1 thru 6	1	2PE29B
1	FLUID CYLINDER .....	1	2PE29
2	STUD, Cylinder to Frame .....	12	79AB9
3	NUT, Cylinder to Frame.....	12	50B34
4	NUT, Valve Cover Stud .....	12	50B10
5	STUD, Valve Cover to Cylinder .....	12	79L1
6	NUT, Cylinder Stuffing Box.....	12	50B32
7	COVER-VALVE .....	6	3PE147
8	GASKET, Valve Cover .....	6	25AL36
9	GASKET, Manifold to Cylinder .....	3	25AL62
10	MANIFOLD, Suction .....	1	8PE110
11	SCREW, Manifold to Cylinder .....	12	655EF060
12	PLUG, Manifold .....	3	64AJ16
14	FLANGE, Suction (Steel - Threaded).....	2	64CA13 *
15	GASKET, Flange .....	2	25C861N *
16	SCREW, Suction Flange .....	16	655EG080 *
17	NUT, Flange Screw .....	16	50B8 *

\* These parts are not standard equipment, but are furnished when ordered.

Order by Part Number and Description. Reference Numbers are shown for your convenience only.

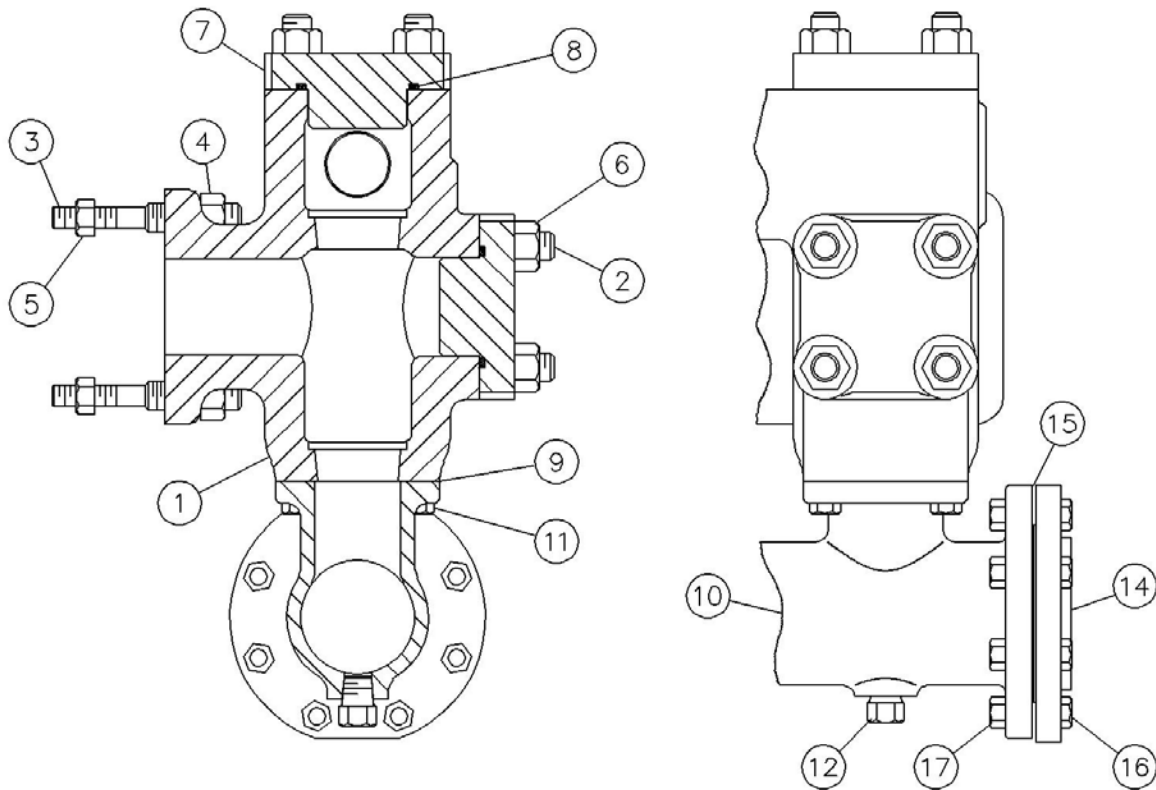

Ref. Drawing – 315TEE799

**FLUID END (TEEB) (3x5)**  
**Medium Pressure Cast Aluminum Bronze Cylinder – 3”**

Ref No.	Description	Qty.	Part No.
	FLUID CYLINDER ASSEMBLY, Includes Ref No's: 1 thru 6.....	1	3PE29B
1	FLUID CYLINDER .....	1	3PE29
2	STUD, Valve Cover to Cylinder .....	24	79AJ5
3	STUD, Cylinder to Frame .....	12	79AB16
4	NUT, Cylinder to Frame Stud .....	12	50B34
5	NUT, Cylinder Stuffing Box.....	12	50C9
6	NUT, Valve Cover Stud .....	24	50B34
7	COVER-VALVE .....	6	4PE147
8	GASKET, Valve Cover .....	6	25AL35
9	GASKET, Manifold to Cylinder .....	3	25BE27
10	MANIFOLD, Suction .....	1	6PE110
11	SCREW, Manifold to Cylinder .....	12	655EF060
12	PLUG, Manifold .....	3	64AJ16
14	FLANGE, Suction (Steel - Threaded) .....	2	64CA11 *
15	GASKET, Flange .....	2	25C121N *
16	SCREW, Suction Flange .....	16	655EF100 *
17	NUT, Flange Screw .....	16	50B7 *

\* These parts are not standard equipment, but are furnished when ordered.

Order by Part Number and Description. Reference Numbers are shown for your convenience only.

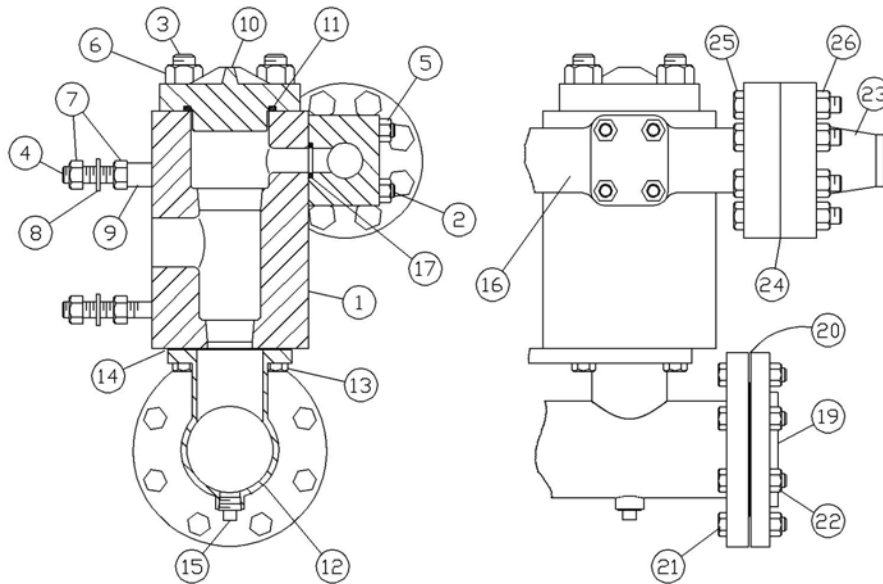

Ref. Drawing – 316TEE799

**FLUID END (TEEC) (2x5)  
High Pressure Block Steel Cylinder – 2”**

Ref No.	Description	Qty.	Part No.
	FLUID CYLINDER ASSEMBLY, Includes Ref No's: 1 thru 9.....	3	200PEE029B
1	FLUID CYLINDER .....	3	200PEE029
2	STUD, Cylinder to Discharge Manifold.....	12	79AJ1
3	STUD, Valve Cover .....	12	79AJ5
4	STUD, Cylinder to Frame & Stuffing Box .....	12	79AK8
5	NUT, Cylinder to Discharge Manifold Stud.....	12	50B31
6	NUT, Valve Cover Stud .....	12	50B34
7	NUT, Cylinder to Frame & Stuffing Box Stud .....	24	50B32
8	WASHER, Cylinder to Stuffing Box .....	12	95U8
9	SPACER, Fluid Cylinder to Frame .....	6	80C44
10	COVER-VALVE .....	3	7PE147
11	GASKET, Valve Cover .....	3	25AL35
12	MANIFOLD-SUCTION.....	1	9PE110
13	SCREW, Suction Manifold to Cylinder .....	12	655EF060
14	GASKET, Suction Manifold to Cylinder .....	3	25C1271N
15	PLUG, Suction Manifold .....	3	64AA3
16	MANIFOLD-DISCHARGE .....	1	200PEE071
17	GASKET, Cylinder to Discharge Manifold.....	3	25BC86
19	FLANGE, SUCTION (Steel - Threaded).....	2	64CA11 *
20	GASKET, Suction Flange .....	2	25C121N *
21	SCREW, Suction Flange .....	16	655EF100 *
22	NUT, Suction Flange Screw .....	16	50B7 *
23	FLANGE, Discharge Manifold (Steel – Weld Neck) .....	2	2009760 *
24	GASKET, Discharge Manifold Flange .....	2	2009761 *
25	SCREW, Discharge Manifold Flange .....	16	655EG180 *
26	NUT, Discharge Manifold Flange Screw .....	16	50B32

\* These parts are not standard equipment, but are furnished when ordered.

Order by Part Number and Description. Reference Numbers are shown for your convenience only.

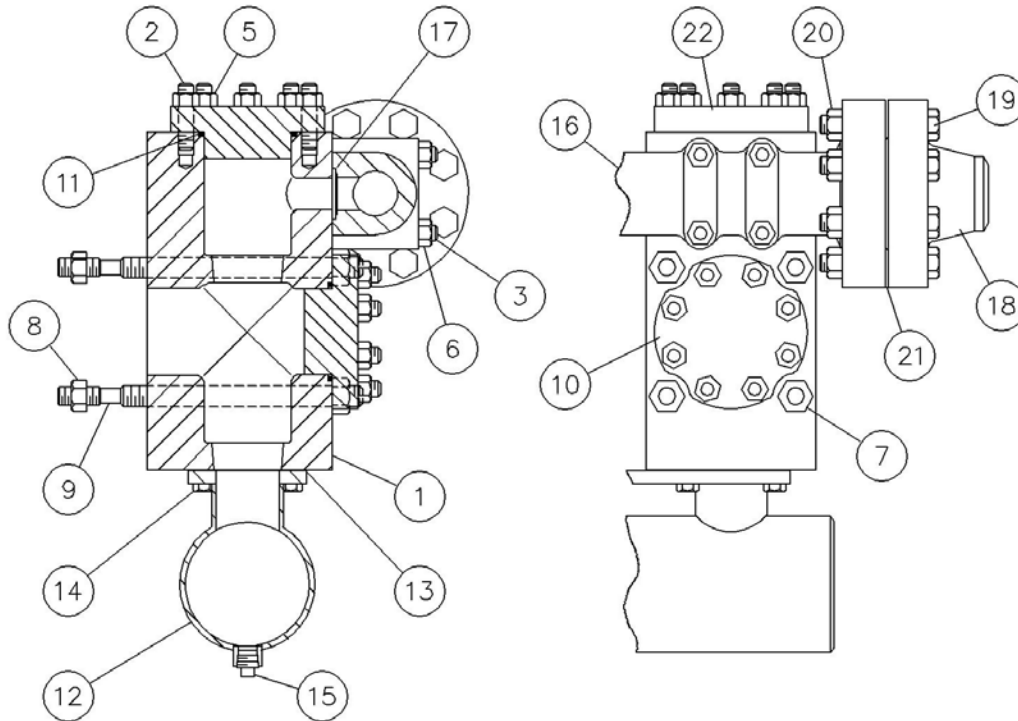

Ref. Drawing – 317TEE799

**FLUID END (TEED & TEE) (4x5)  
High Pressure Block Steel Cylinder – 4"**

Ref No.	Description	Qty.	Part No.
	FLUID CYLINDER ASSEMBLY, Includes Ref No's: 1 thru 7.....	3	200TEE029B
1	FLUID CYLINDER .....	3	200TEE029
2	STUD, Valve Cover .....	48	201TEE110
3	STUD, Cylinder to Discharge Manifold.....	12	79L96
5	NUT, Valve Cover Stud .....	48	50B32
6	NUT, Cylinder to Discharge Manifold Stud.....	12	50B32
7	NUT, Cylinder to Frame Stud .....	12	50B34
8	NUT, Cylinder to Frame & Stuffing Box.....	12	50AQ30
9	STUD, Cylinder to Frame & Stuffing Box .....	12	200TEE110
10	COVER-VALVE, Suction .....	3	200TEE147
11	GASKET, Valve Cover.....	6	303TEE718
12	MANIFOLD-SUCTION.....	1	200PEE069
13	GASKET, Suction Manifold to Cylinder .....	3	25C1271N
14	SCREW, Suction Manifold to Cylinder .....	12	655EF060
15	PLUG, Suction Manifold .....	1	64AA3
16	MANIFOLD-DISCHARGE .....	1	200TEE071
17	GASKET, Cylinder to Discharge Manifold.....	3	25AL59
18	FLANGE, Discharge (Steel – Weld Neck).....	2	64EB37 *
19	SCREW, Flange to Discharge Manifold .....	16	75A231
20	NUT, Discharge Flange .....	16	50B9 *
21	GASKET, Discharge Flange.....	2	25BC42 *
22	COVER-VALVE, Discharge.....	3	PP1005549 *

\* These parts are not standard equipment, but are furnished when ordered.

Order by Part Number and Description. Reference Numbers are shown for your convenience only.

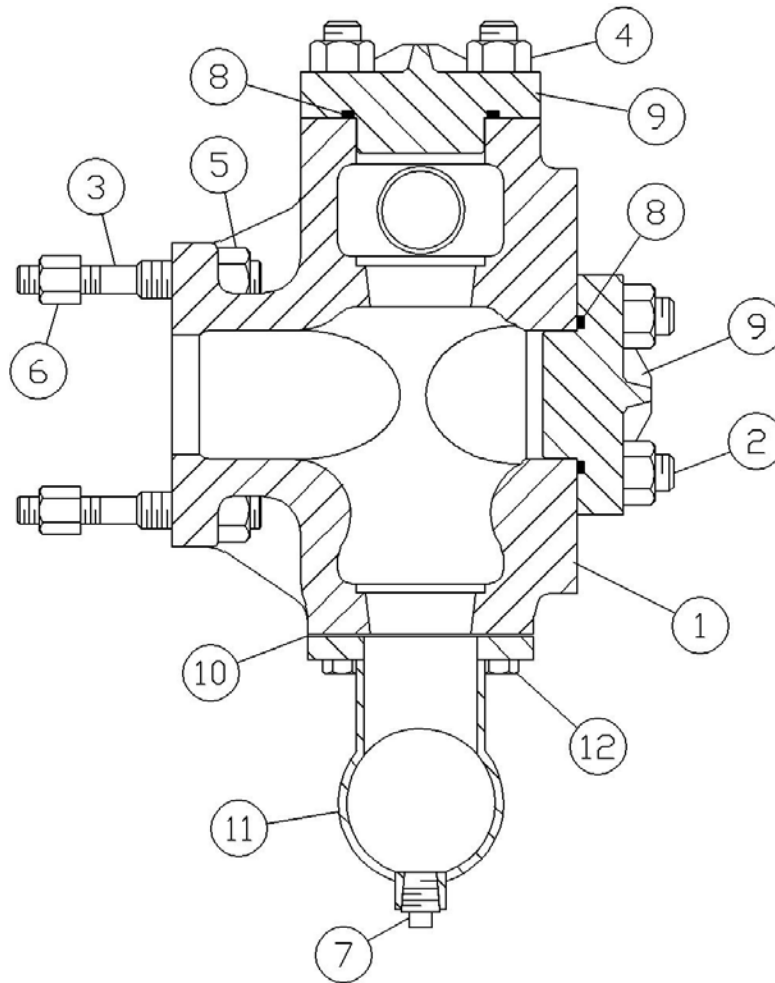

Ref. Drawing – 318TEE799

**FLUID END (TEEF & TEEG) (3x5)  
High Pressure Cast Steel Cylinder – 3”**

Ref No.	Description	Qty.	Part No.
	FLUID CYLINDER ASSEMBLY, Includes Ref No's: 1 thru 6.....	1	4PE29B
1	FLUID CYLINDER .....	1	4PE29
2	STUD, Valve Cover to Cylinder .....	24	79AJ5
3	STUD, Cylinder to Frame .....	12	79AB16
4	NUT, Valve Cover Stud .....	24	50B34
5	NUT, Cylinder to Frame Stud .....	12	50B34
6	NUT, Cylinder to Frame & Stuffing Box.....	12	50T90
7	PLUG, Manifold .....	3	64AA3
8	GASKET, Valve Cover .....	6	25AL35
9	COVER-VALVE .....	6	7PE147
10	GASKET, Suction Manifold to Cylinder .....	3	25C1271N
11	MANIFOLD, Suction 4 inch (Standard) .....	1	4PE110
	MANIFOLD, Suction 6 inch (Optional).....	1	200PEE069
12	SCREW, Suction Manifold to Cylinder .....	12	655EF060

Order by Part Number and Description. Reference Numbers are shown for your convenience only.

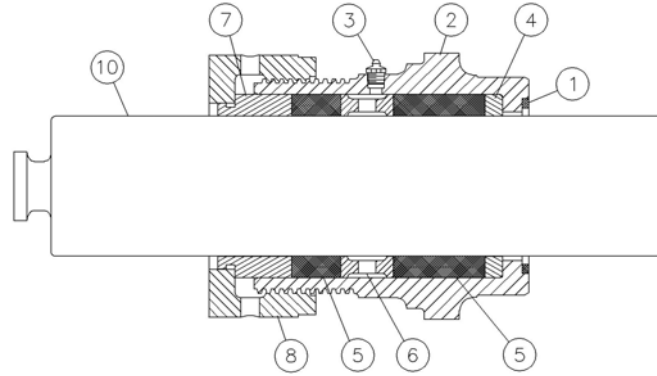

Ref. Drawing – 319TEE799

**STUFFING BOX, PLUNGERS & PACKING (TEEA)**  
**Low Pressure Cast Aluminum Bronze Cylinder**  
**STYLE 838 PACKING**

Ref. No.	Name of Part	Qty.	4.00"	3.50"	3.25"	3.00"
			Part No.	Part No.	Part No.	Part No.
1	GASKET .....	3	25AL36	25AL36	25AL36	25AL36
2	STUFFING BOX, Includes Ref No.3	3	8PE14	9PE14	23PE14	10PE14
3	LUBE FITTING .....	3	40E7	40E7	40E7	40E7
<b>STYLE 838 PACKING GROUP</b>						
	Includes Ref. Numbers 4 thru 7 .....	3	63PE1600	64PE1600	51PE1600	65PE1600
4	JUNK RING .....	3	38PE317	36PE317	41PE317	26PE317
5	PACKING – <b>STYLE 838</b> .....	3	60BU72	60BU73	60BU71	60BU74
6	LANTERN SPACER .....	3	31PE445	33PE445	28PE445	34PE445
7	GLAND BUSHING .....	3	28PE152	29PE152	41PE152	30PE152
8	GLAND NUT .....	3	2PE113	2PE113	3PE113	3PE113
9 *	PIN, Gland Nut tightening .....	3	62L72	62L72	62L72	62L72
10	PLUNGER (Colmonoy) .....	3	1PE3840	1PE3835	1PE3832	302TEE038
10	PLUNGER (Ceramic) .....	3	PE3840	PE3835	PE3832	PE3830
10	PLUNGER (Chrome Plated) .....	3	3PE3840	3PE3835	3PE3832	3PE3830

**STYLE 858 PACKING**

Ref. No.	Name of Part	Qty.	4.00"	3.50"	3.25"	3.00"
			Part No.	Part No.	Part No.	Part No.
1	GASKET .....	3	25AL36	25AL36	25AL36	25AL36
2	STUFFING BOX, Includes Ref No.3	3	8PE14	9PE14	23PE14	10PE14
3	LUBE FITTING .....	3	40E7	40E7	40E7	40E7
<b>STYLE 858 PACKING GROUP</b>						
	Includes Ref. Numbers 4 thru 7 .....	3	300TEE4060	301TEE4060	302TEE4060	303TEE4060
4	JUNK RING .....	3	38PE317	36PE317	41PE317	26PE317
5	PACKING – <b>STYLE 858</b> .....	3	60DD763	60DD761	60DD760	60DD759
6	LANTERN SPACER .....	3	31PE445	33PE445	28PE445	34PE445
7	GLAND BUSHING .....	3	28PE152	29PE152	41PE152	30PE152
8	GLAND NUT .....	3	2PE113	2PE113	3PE113	3PE113
9 *	PIN, Gland Nut tightening .....	3	62L72	62L72	62L72	62L72
10	PLUNGER (Colmonoy) .....	3	1PE3840	1PE3835	1PE3832	302TEE038
10	PLUNGER (Ceramic) .....	3	PE3840	PE3835	PE3832	PE3830
10	PLUNGER (Chrome Plated) .....	3	3PE3840	3PE3835	3PE3832	3PE3830

\* Not shown

Order by Part Number and Description. Reference Numbers are shown for your convenience only.

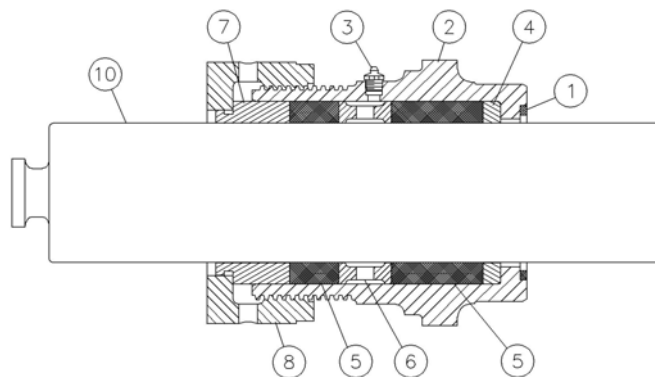

Ref. Drawing – 319TEE799

**STUFFING BOX, PLUNGERS & PACKING (TEEB)**  
**Medium Pressure Cast Aluminum Bronze Cylinder**  
**STYLE 838 PACKING**

Ref. No.	Name of Part	Qty.	3.00"	2.75"	2.50"	2.25"
			Part No.	Part No.	Part No.	Part No.
1	GASKET .....	3	25AL36	25AL35	25AL35	25AL35
2	STUFFING BOX, Includes Ref No.3	3	10PE14	11PE14	12PE14	13PE14
3	LUBE FITTING .....	3	40E7	40E7	40E7	40E7
<b>STYLE 838 PACKING GROUP</b>						
	Includes Ref. Numbers 4 thru 7 .....	3	65PE1600	66PE1600	67PE1600	68PE1600
4	JUNK RING .....	3	26PE317	27PE317	28PE317	25PE317
5	PACKING – <b>STYLE 838</b> .....	3	60BU74	60BU75	60BU76	60BU77
6	LANTERN SPACER .....	3	34PE445	35PE445	36PE445	37PE445
7	GLAND BUSHING .....	3	30PE152	31PE152	32PE152	27PE152
8	GLAND NUT .....	3	3PE113	3PE113	3PE113	3PE113
9 *	PIN, Gland Nut tightening .....	3	62L72	62L72	62L72	62L72
10	PLUNGER (Colmonoy) .....	3	302TEE038	1PE3827	1PE3825	1PE3822
10	PLUNGER (Ceramic) .....	3	PE3830	PE3827	PE3825	PE3822
10	PLUNGER (Chrome Plated) .....	3	3PE3830	3PE3827	3PE3825	3PE3822

**STYLE 858 PACKING**

Ref. No.	Name of Part	Qty.	3.00"	2.75"	2.50"	2.25"
			Part No.	Part No.	Part No.	Part No.
1	GASKET .....	3	25AL36	25AL35	25AL35	25AL35
2	STUFFING BOX, Includes Ref No.3	3	10PE14	11PE14	12PE14	13PE14
3	LUBE FITTING .....	3	40E7	40E7	40E7	40E7
<b>STYLE 858 PACKING GROUP</b>						
	Includes Ref. Numbers 4 thru 7 .....	3	303TEE4060	304TEE4060	305TEE4060	306TEE4060
4	JUNK RING .....	3	26PE317	27PE317	28PE317	25PE317
5	PACKING – <b>STYLE 858</b> .....	3	60DD759	60DD758	60DD757	60DD756
6	LANTERN SPACER .....	3	34PE445	35PE445	36PE445	37PE445
7	GLAND BUSHING .....	3	30PE152	31PE152	32PE152	27PE152
8	GLAND NUT .....	3	3PE113	3PE113	3PE113	3PE113
9 *	PIN, Gland Nut tightening .....	3	62L72	62L72	62L72	62L72
10	PLUNGER (Colmonoy) .....	3	302TEE038	1PE3827	1PE3825	1PE3822
10	PLUNGER (Ceramic) .....	3	PE3830	PE3827	PE3825	PE3822
10	PLUNGER (Chrome Plated) .....	3	3PE3830	3PE3827	3PE3825	3PE3822

\* Not shown

Order by Part Number and Description. Reference Numbers are shown for your convenience only.

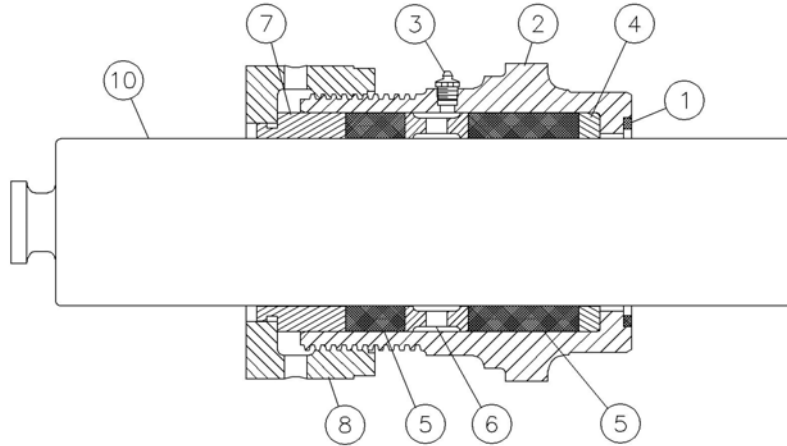

Ref. Drawing – 319TEE799

**STUFFING BOX, PLUNGERS & PACKING (TEEC)**  
**3 Piece High Pressure Block Steel Cylinder**  
**STYLE 838 PACKING**

Ref. No.	Name of Part	Qty.	2.00" Part No.	1.75" Part No.	1.50" Part No.
1	GASKET .....	3	25BD3	25BD3	25BD3
2	STUFFING BOX, Includes Ref No.3	3	34PE14	35PE14	35PE14
3	LUBE FITTING .....	3	40E7	40E7	40E7
<b>STYLE 838 PACKING GROUP</b>					
	Includes Ref. Numbers 4 thru 7 .....	3	PS160020	PS160017	PS160015
4	JUNK RING .....	3	PQ31720	PQ31717	PQ31715
5	PACKING – <b>STYLE 838</b> .....	3	60BU97	60BU31	60BU98
6	LANTERN SPACER.....	3	PQ44520	PQ44517	PQ44515
7	GLAND BUSHING.....	3	PS15220	PS15217	PS15215
8	GLAND NUT.....	3	2011555	2011555	2011555
9 *	PIN, Gland Nut tightening .....	3	62L45	62L45	62L45
10	PLUNGER (Colmonoy) .....	3	11PE3820	11PE3817	11PE3815
10	PLUNGER (Tungsten Carbide).....	3	200TEE038	202TEE038	204TEE038

**STYLE 858 PACKING**

Ref. No.	Name of Part	Qty.	2.00" Part No.	1.75" Part No.	1.50" Part No.
1	GASKET.....	3	25BD3	25BD3	25BD3
2	STUFFING BOX, Includes Ref No.3	3	34PE14	35PE14	35PE14
3	LUBE FITTING .....	3	40E7	40E7	40E7
<b>STYLE 858 PACKING GROUP</b>					
	Includes Ref. Numbers 4 thru 7 .....	3	307TEE4060	308TEE4060	309TEE4060
4	JUNK RING .....	3	PQ31720	PQ31717	PQ31715
5	PACKING – <b>STYLE 858</b> .....	3	60DD768	60DD754	60DD766
6	LANTERN SPACER.....	3	PQ44520	PQ44517	PQ44515
7	GLAND BUSHING.....	3	PS15220	PS15217	PS15215
8	GLAND NUT.....	3	2011555	2011555	2011555
9 *	PIN, Gland Nut tightening .....	3	62L45	62L45	62L45
10	PLUNGER (Colmonoy) .....	3	11PE3820	11PE3817	11PE3815
10	PLUNGER (Tungsten Carbide).....	3	200TEE038	202TEE038	204TEE038

\* Not shown

Order by Part Number and Description. Reference Numbers are shown for your convenience only.

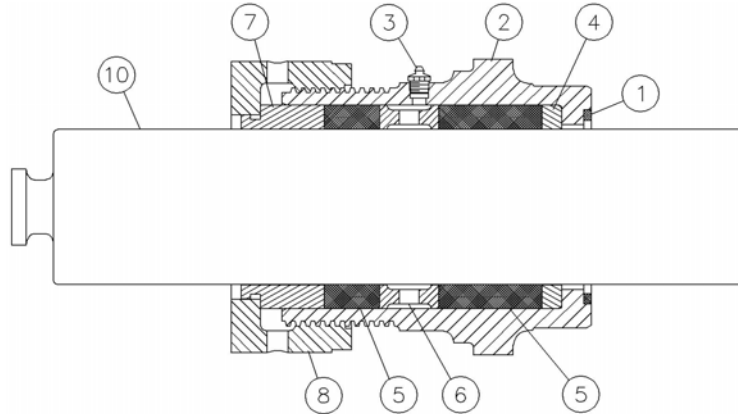

Ref. Drawing – 319TEE799

**STUFFING BOX, PLUNGERS & PACKING (TEEC)**  
**3 Piece High Pressure Block Steel Cylinder**

**STYLE 838 PACKING**

Ref. No.	Name of Part	Qty.	1.25" Part No.
1	GASKET .....	3	25BD3
2	STUFFING BOX, Includes Ref No.3	3	36PE14
3	LUBE FITTING.....	3	40E7
<b>STYLE 838 PACKING GROUP</b>			
	Includes Ref. Numbers 4 thru 7 .....	3	PS160012
4	JUNK RING.....	3	PQ31712
5	PACKING – <b>STYLE 838</b> .....	3	60BU33
6	LANTERN SPACER .....	3	PQ44512
7	GLAND BUSHING .....	3	PS15212
8	GLAND NUT .....	3	2011555
9 *	PIN, Gland Nut tightening .....	3	62L45
10	PLUNGER (Colmonoy).....	3	11PE3812
10	PLUNGER (Tungsten Carbide) .....	3	206TEE038

**STYLE 858 PACKING**

Ref. No.	Name of Part	Qty.	1.25" Part No.
1	GASKET .....	3	25BD3
2	STUFFING BOX, Includes Ref No.3	3	36PE14
3	LUBE FITTING.....	3	40E7
<b>STYLE 858 PACKING GROUP</b>			
	Includes Ref. Numbers 4 thru 7 .....	3	310TEE4060
4	JUNK RING.....	3	PQ31712
5	PACKING – <b>STYLE 858</b> .....	3	60DD752
6	LANTERN SPACER .....	3	PQ44512
7	GLAND BUSHING .....	3	PS15212
8	GLAND NUT .....	3	2011555
9 *	PIN, Gland Nut tightening .....	3	62L45
10	PLUNGER (Colmonoy).....	3	11PE3812
10	PLUNGER (Tungsten Carbide) .....	3	206TEE038

\* Not shown

Order by Part Number and Description. Reference Numbers are shown for your convenience only.

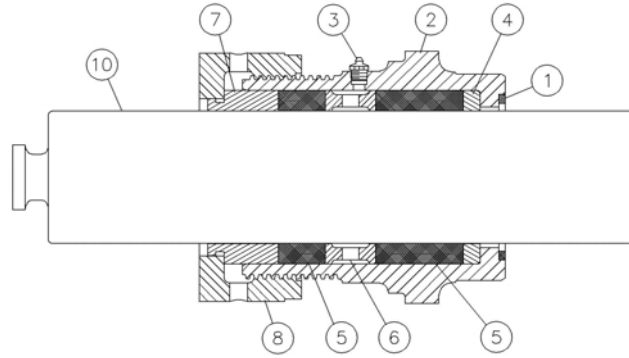

Ref. Drawing – 319TEE799

**STUFFING BOX, PLUNGERS & PACKING (TEED)**  
**3 Piece High Pressure Block Steel Cylinder**  
**STYLE 838 PACKING**

Ref. No.	Name of Part	Qty.	4.00" Part No.	3.50" Part No.	3.00" Part No.	2.75" Part No.
1	GASKET .....	3	303TEE718	303TEE718	303TEE718	303TEE718
2	STUFFING BOX, Includes Ref No.3	3	200TEE014	201TEE014	202TEE014	203TEE014
3	LUBE FITTING .....	3	40E7	40E7	40E7	40E7
	<b>STYLE 838 PACKING GROUP</b>					
	Includes Ref. Numbers 4 thru 7 .....	3	63PE1600	64PE1600	65PE1600	66PE1600
4	JUNK RING .....	3	38PE317	36PE317	26PE317	27PE317
5	PACKING – <b>STYLE 838</b> .....	3	60BU72	60BU73	60BU74	60BU75
6	LANTERN SPACER .....	3	31PE445	33PE445	34PE445	35PE445
7	GLAND BUSHING .....	3	28PE152	29PE152	30PE152	31PE152
8	GLAND NUT .....	3	200PEE008	200PEE008	4PE113	4PE113
9 *	PIN, Gland Nut tightening .....	3	62L72	62L72	62L72	62L72
10	PLUNGER (Colmonoy) .....	3	1PE3840	1PE3835	302TEE038	1PE3827
10	PLUNGER (Ceramic) .....	3	PE3840	PE3835	PE3830	PE3827
10	PLUNGER (Chrome Plated) .....	3	3PE3840	3PE3835	3PE3830	3PE3827

**STYLE 838 PACKING**

Ref. No.	Name of Part	Qty.	2.50" Part No.	2.25" Part No.	2.00" Part No.	1.75" Part No.
1	GASKET .....	3	303TEE718	303TEE718	303TEE718	303TEE718
2	STUFFING BOX, Includes Ref No.3	3	204TEE014	205TEE014	206TEE014	207TEE014
3	LUBE FITTING .....	3	40E7	40E7	40E7	40E7
	<b>STYLE 838 PACKING GROUP</b>					
	Includes Ref. Numbers 4 thru 7 .....	3	67PE1600	68PE1600	69PE1600	70PE1600
4	JUNK RING .....	3	28PE317	25PE317	29PE317	30PE317
5	PACKING – <b>STYLE 838</b> .....	3	60BU76	60BU77	60BU78	60BU79
6	LANTERN SPACER .....	3	36PE445	37PE445	38PE445	39PE445
7	GLAND BUSHING .....	3	32PE152	27PE152	33PE152	34PE152
8	GLAND NUT .....	3	4PE113	4PE113	4PE113	4PE113
9 *	PIN, Gland Nut tightening .....	3	62L72	62L72	62L72	62L72
10	PLUNGER (Colmonoy) .....	3	1PE3825	1PE3822	1PE3820	1PE3817
10	PLUNGER (Ceramic) .....	3	PE3825	PE3822	PE3820	PE3817
10	PLUNGER (Chrome Plated) .....	3	3PE3825	3PE3822	3PE3820	3PE3817

\* Not shown

Order by Part Number and Description. Reference Numbers are shown for your convenience only.

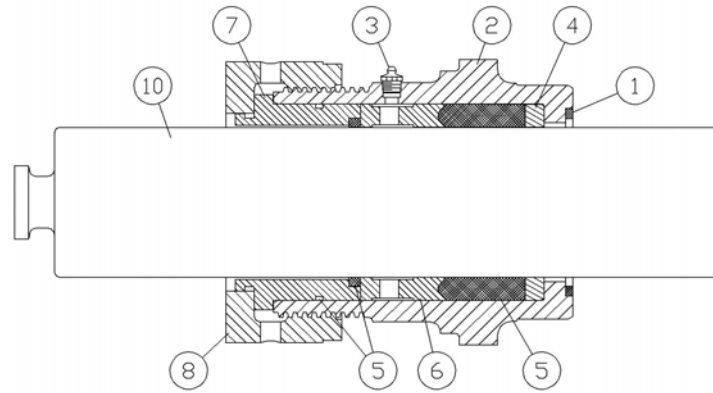

Ref. Drawing – 320TEE799

**STUFFING BOX, PLUNGERS & PACKING (TEED)**  
**3 Piece High Pressure Block Steel Cylinder**  
**STYLE 1067 PACKING**

Ref. No.	Name of Part	Qty.	4.00"			
			Part No.	Part No.	Part No.	Part No.
1	GASKET .....	3	303TEE718	303TEE718	303TEE718	303TEE718
2	STUFFING BOX, Includes Ref No.3	3	200TEE014	201TEE014	202TEE014	203TEE014
3	LUBE FITTING .....	3	40E7	40E7	40E7	40E7
<b>STYLE 1067 PACKING GROUP</b>						
	Includes Ref. Numbers 4 thru 7.....	3	TEE77906	TEE77907	TEE77908	TEE77909
4	JUNK RING .....	3	200TEE317	201TEE317	202TEE317	203TEE317
5	PACKING – <b>STYLE 1067</b> .....	3	60DD116	60DD115	60DD113	60DD112
6	LANTERN SPACER .....	3	200TEE445	201TEE445	202TEE445	203TEE445
7	GLAND BUSHING .....	3	200TEE152	201TEE152	202TEE152	203TEE152
8	GLAND NUT .....	3	200PEE008	200PEE008	4PE113	4PE113
9 *	PIN, Gland Nut tightening.....	3	62L72	62L72	62L72	62L72
10	PLUNGER (Colmonoy).....	3	1PE3840	1PE3835	302TEE038	1PE3827
10	PLUNGER (Ceramic) .....	3	PE3840	PE3835	PE3830	PE3827
10	PLUNGER (Chrome Plated).....	3	3PE3840	3PE3835	3PE3830	3PE3827

**STYLE 1067 PACKING**

Ref. No.	Name of Part	Qty.	2.50"			
			Part No.	Part No.	Part No.	Part No.
1	GASKET .....	3	303TEE718	303TEE718	303TEE718	303TEE718
2	STUFFING BOX, Includes Ref No.3	3	204TEE014	205TEE014	206TEE014	207TEE014
3	LUBE FITTING .....	3	40E7	40E7	40E7	40E7
<b>STYLE 1067 PACKING GROUP</b>						
	Includes Ref. Numbers 4 thru 7.....	3	TEE77910	TEE77911	TEE77912	TEE77913
4	JUNK RING .....	3	204TEE317	205TEE317	206TEE317	207TEE317
5	PACKING – <b>STYLE 1067</b> .....	3	60DD111	60DD110	60DD109	60DD108
6	LANTERN SPACER .....	3	204TEE445	205TEE445	206TEE445	207TEE445
7	GLAND BUSHING .....	3	204TEE152	205TEE152	206TEE152	207TEE152
8	GLAND NUT .....	3	4PE113	4PE113	4PE113	4PE113
9 *	PIN, Gland Nut tightening.....	3	62L72	62L72	62L72	62L72
10	PLUNGER (Colmonoy).....	3	1PE3825	1PE3822	1PE3820	1PE3817
10	PLUNGER (Ceramic) .....	3	PE3825	PE3822	PE3820	PE3817
10	PLUNGER (Chrome Plated).....	3	3PE3825	3PE3822	3PE3820	3PE3817

\* Not shown

Order by Part Number and Description. Reference Numbers are shown for your convenience only.

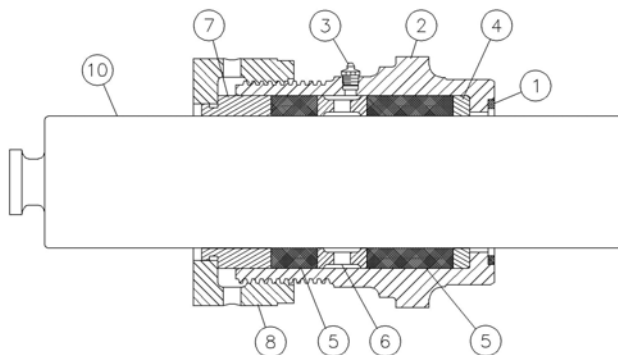

Ref. Drawing – 319TEE799

**STUFFING BOX, PLUNGERS & PACKING (TEED)**  
**3 Piece High Pressure Block Steel Cylinder**  
**STYLE 858 PACKING**

Ref. No.	Name of Part	Qty.	4.00"	3.50"	3.00"	2.75"
			Part No.	Part No.	Part No.	Part No.
1	GASKET .....	3	303TEE718	303TEE718	303TEE718	303TEE718
2	STUFFING BOX, Includes Ref No.3	3	200TEE014	201TEE014	202TEE014	203TEE014
3	LUBE FITTING .....	3	40E7	40E7	40E7	40E7
<b>STYLE 858 PACKING GROUP</b>						
	Includes Ref. Numbers 4 thru 7 .....	3	300TEE4060	301TEE4060	303TEE4060	304TEE4060
4	JUNK RING .....	3	38PE317	36PE317	26PE317	27PE317
5	PACKING – <b>STYLE 858</b> .....	3	60DD763	60DD761	60DD759	60DD758
6	LANTERN SPACER .....	3	31PE445	33PE445	34PE445	35PE445
7	GLAND BUSHING .....	3	28PE152	29PE152	30PE152	31PE152
8	GLAND NUT .....	3	200PEE008	200PEE008	4PE113	4PE113
9 *	PIN, Gland Nut tightening .....	3	62L72	62L72	62L72	62L72
10	PLUNGER (Colmonoy) .....	3	1PE3840	1PE3835	302TEE038	1PE3827
10	PLUNGER (Ceramic) .....	3	PE3840	PE3835	PE3830	PE3827
10	PLUNGER (Chrome Plated) .....	3	3PE3840	3PE3835	3PE3830	3PE3827

**STYLE 858 PACKING**

Ref. No.	Name of Part	Qty.	2.50"	2.25"	2.00"	1.75"
			Part No.	Part No.	Part No.	Part No.
1	GASKET .....	3	303TEE718	303TEE718	303TEE718	303TEE718
2	STUFFING BOX, Includes Ref No.3	3	204TEE014	205TEE014	206TEE014	207TEE014
3	LUBE FITTING .....	3	40E7	40E7	40E7	40E7
<b>STYLE 858 PACKING GROUP</b>						
	Includes Ref. Numbers 4 thru 7 .....	3	305TEE4060	306TEE4060	311TEE4060	312TEE4060
4	JUNK RING .....	3	28PE317	25PE317	29PE317	30PE317
5	PACKING – <b>STYLE 858</b> .....	3	60DD757	60DD756	60DD768	60DD767
6	LANTERN SPACER .....	3	36PE445	37PE445	38PE445	39PE445
7	GLAND BUSHING .....	3	32PE152	27PE152	33PE152	34PE152
8	GLAND NUT .....	3	4PE113	4PE113	4PE113	4PE113
9 *	PIN, Gland Nut tightening .....	3	62L72	62L72	62L72	62L72
10	PLUNGER (Colmonoy) .....	3	1PE3825	1PE3822	1PE3820	1PE3817
10	PLUNGER (Ceramic) .....	3	PE3825	PE3822	PE3820	PE3817
10	PLUNGER (Chrome Plated) .....	3	3PE3825	3PE3822	3PE3820	3PE3817

\* Not shown

Order by Part Number and Description. Reference Numbers are shown for your convenience only.

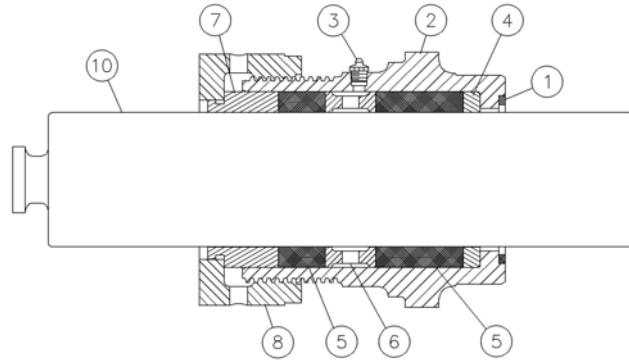

Ref. Drawing – 319TEE799

**STUFFING BOX, PLUNGERS & PACKING (TEEF)**  
**1 Piece High Pressure Cast Steel Cylinder**  
**STYLE 838 PACKING**

Ref. No.	Name of Part	Qty.	3.00" Part No.	2.75" Part No.	2.50" Part No.
1	GASKET .....	3	25AL53	25AL53	25AL53
2	STUFFING BOX, Includes Ref No.3	3	25PE14	26PE14	27PE14
3	LUBE FITTING .....	3	40E7	40E7	40E7
<b>STYLE 838 PACKING GROUP</b>					
	Includes Ref. Numbers 4 thru 7 .....	3	65PE1600	66PE1600	67PE1600
4	JUNK RING .....	3	26PE317	27PE317	28PE317
5	PACKING – <b>STYLE 838</b> .....	3	60BU74	60BU75	60BU76
6	LANTERN SPACER.....	3	34PE445	35PE445	36PE445
7	GLAND BUSHING.....	3	30PE152	31PE152	32PE152
8	GLAND NUT.....	3	4PE113	4PE113	4PE113
9 *	PIN, Gland Nut tightening .....	3	62L72	62L72	62L72
10	PLUNGER (Colmonoy) .....	3	302TEE038	1PE3827	1PE3825
10	PLUNGER (Ceramic) .....	3	PE3830	PE3827	PE3825
10	PLUNGER (Chrome Plated) .....	3	3PE3830	3PE3827	3PE3825

**STYLE 838 PACKING**

Ref. No.	Name of Part	Qty.	2.25" Part No.	2.00" Part No.	1.75" Part No.
1	GASKET .....	3	25AL53	25AL53	25AL53
2	STUFFING BOX, Includes Ref No.3	3	28PE14	29PE14	30PE14
3	LUBE FITTING .....	3	40E7	40E7	40E7
<b>STYLE 838 PACKING GROUP</b>					
	Includes Ref. Numbers 4 thru 7 .....	3	68PE1600	69PE1600	70PE1600
4	JUNK RING .....	3	25PE317	29PE317	30PE317
5	PACKING – <b>STYLE 838</b> .....	3	60BU77	60BU78	60BU79
6	LANTERN SPACER.....	3	37PE445	38PE445	39PE445
7	GLAND BUSHING.....	3	27PE152	33PE152	34PE152
8	GLAND NUT.....	3	4PE113	4PE113	4PE113
9 *	PIN, Gland Nut tightening .....	3	62L72	62L72	62L72
10	PLUNGER (Colmonoy) .....	3	1PE3822	1PE3820	1PE3817
10	PLUNGER (Ceramic) .....	3	PE3822	PE3820	PE3817
10	PLUNGER (Chrome Plated) .....	3	3PE3822	3PE3820	3PE3817

\* Not shown

Order by Part Number and Description. Reference Numbers are shown for your convenience only.

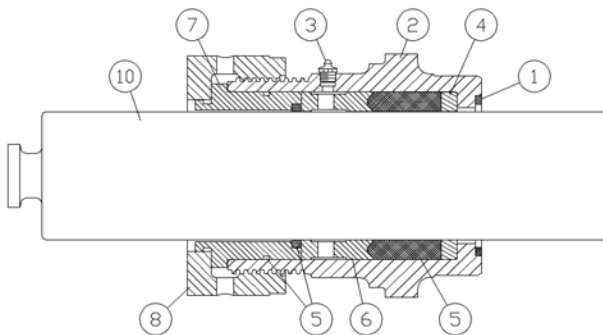

Ref. Drawing – 320TEE799

**STUFFING BOX, PLUNGERS & PACKING (TEEF)**  
**1 Piece High Pressure Cast Steel Cylinder**  
**STYLE 1067 PACKING**

Ref. No.	Name of Part	Qty.	3.00" Part No.	2.75" Part No.	2.50" Part No.
1	GASKET .....	3	25AL53	25AL53	25AL53
2	STUFFING BOX, Includes Ref No.3	3	25PE14	26PE14	27PE14
3	LUBE FITTING .....	3	40E7	40E7	40E7
	<b>STYLE 1067 PACKING GROUP</b>				
	Includes Ref. Numbers 4 thru 7 .....	3	TEE77908	TEE77909	TEE77910
4	JUNK RING .....	3	202TEE317	203TEE317	204TEE317
5	PACKING – <b>STYLE 1067</b> .....	3	60DD113	60DD112	60DD111
6	LANTERN SPACER.....	3	202TEE445	203TEE445	204TEE445
7	GLAND BUSHING.....	3	202TEE152	203TEE152	204TEE152
8	GLAND NUT.....	3	4PE113	4PE113	4PE113
9 *	PIN, Gland Nut tightening .....	3	62L72	62L72	62L72
10	PLUNGER (Colmonoy) .....	3	302TEE038	1PE3827	1PE3825
10	PLUNGER (Ceramic) .....	3	PE3830	PE3827	PE3825
10	PLUNGER (Chrome Plated) .....	3	3PE3830	3PE3827	3PE3825

**STYLE 1067 PACKING**

Ref. No.	Name of Part	Qty.	2.25" Part No.	2.00" Part No.	1.75" Part No.
1	GASKET .....	3	25AL53	25AL53	25AL53
2	STUFFING BOX, Includes Ref No.3	3	28PE14	29PE14	30PE14
3	LUBE FITTING .....	3	40E7	40E7	40E7
	<b>STYLE 1067 PACKING GROUP</b>				
	Includes Ref. Numbers 4 thru 7 .....	3	TEE77911	TEE77912	TEE77913
4	JUNK RING .....	3	205TEE317	206TEE317	207TEE317
5	PACKING – <b>STYLE 1067</b> .....	3	60DD110	60DD109	60DD108
6	LANTERN SPACER.....	3	205TEE445	206TEE445	207TEE445
7	GLAND BUSHING.....	3	205TEE152	206TEE152	207TEE152
8	GLAND NUT.....	3	4PE113	4PE113	4PE113
9 *	PIN, Gland Nut tightening .....	3	62L72	62L72	62L72
10	PLUNGER (Colmonoy) .....	3	1PE3822	1PE3820	1PE3817
10	PLUNGER (Ceramic) .....	3	PE3822	PE3820	PE3817
10	PLUNGER (Chrome Plated) .....	3	3PE3822	3PE3820	3PE3817

\* Not shown

Order by Part Number and Description. Reference Numbers are shown for your convenience only.

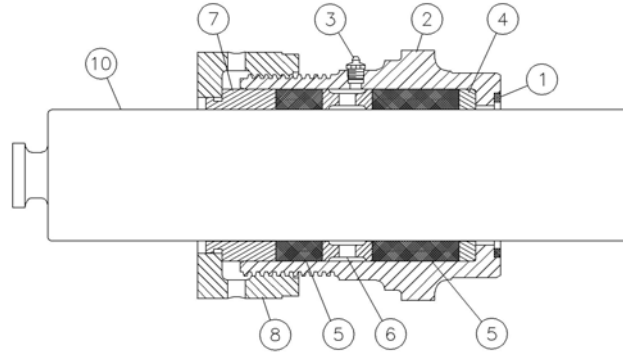

Ref. Drawing – 319TEE799

**STUFFING BOX, PLUNGERS & PACKING (TEEF)**  
**1 Piece High Pressure Cast Steel Cylinder**  
**STYLE 858 PACKING**

Ref. No.	Name of Part	Qty.	3.00" Part No.	2.75" Part No.	2.50" Part No.
1	GASKET .....	3	25AL53	25AL53	25AL53
2	STUFFING BOX, Includes Ref No.3	3	25PE14	26PE14	27PE14
3	LUBE FITTING .....	3	40E7	40E7	40E7
<b>STYLE 858 PACKING GROUP</b>					
	Includes Ref. Numbers 4 thru 7 .....	3	303TEE4060	304TEE4060	305TEE4060
4	JUNK RING .....	3	26PE317	27PE317	28PE317
5	PACKING – <b>STYLE 858</b> .....	3	60DD759	60DD758	60DD757
6	LANTERN SPACER.....	3	34PE445	35PE445	36PE445
7	GLAND BUSHING.....	3	30PE152	31PE152	32PE152
8	GLAND NUT.....	3	4PE113	4PE113	4PE113
9 *	PIN, Gland Nut tightening .....	3	62L72	62L72	62L72
10	PLUNGER (Colmonoy) .....	3	302TEE038	1PE3827	1PE3825
10	PLUNGER (Ceramic) .....	3	PE3830	PE3827	PE3825
10	PLUNGER (Chrome Plated) .....	3	3PE3830	3PE3827	3PE3825

**STYLE 858 PACKING**

Ref. No.	Name of Part	Qty.	2.25" Part No.	2.00" Part No.	1.75" Part No.
1	GASKET .....	3	25AL53	25AL53	25AL53
2	STUFFING BOX, Includes Ref No.3	3	28PE14	29PE14	30PE14
3	LUBE FITTING .....	3	40E7	40E7	40E7
<b>STYLE 858 PACKING GROUP</b>					
	Includes Ref. Numbers 4 thru 7 .....	3	306TEE4060	311TEE4060	312TEE4060
4	JUNK RING .....	3	25PE317	29PE317	30PE317
5	PACKING – <b>STYLE 858</b> .....	3	60DD756	60DD768	60DD767
6	LANTERN SPACER.....	3	37PE445	38PE445	39PE445
7	GLAND BUSHING.....	3	27PE152	33PE152	34PE152
8	GLAND NUT.....	3	4PE113	4PE113	4PE113
9 *	PIN, Gland Nut tightening .....	3	62L72	62L72	62L72
10	PLUNGER (Colmonoy) .....	3	1PE3822	1PE3820	1PE3817
10	PLUNGER (Ceramic) .....	3	PE3822	PE3820	PE3817
10	PLUNGER (Chrome Plated) .....	3	3PE3822	3PE3820	3PE3817

\* Not shown

Order by Part Number and Description. Reference Numbers are shown for your convenience only.

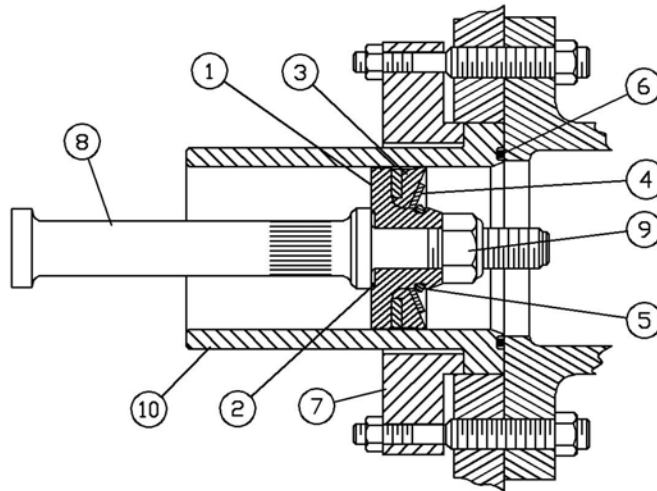

Ref. Drawing - 321TEE799

**PISTONS AND LINERS (TEEE)**  
Well Service – High Pressure Block Steel – 4”

Ref. No.	Name of Part	Qty.	4.00"	3.50"	3.00"	2.75"
			Part No.	Part No.	Part No.	Part No.
1	PISTON BODY ASSEMBLY..... Includes Ref No's 2 & 3	3	232TBA045A	230TBA045A	228TBA045A	227TBA045A
2	O-RING.....	3	25AH1	25AH1	25AH1	25AH1
3	INSERT GROUP, Includes Ref. .... Numbers 4 and 5	3	TBA76008	TBA76006	TBA76004	TBA76003
4	PLATE-RETAINER.....	3	*	*	*	*
5	RING-RETAINER.....	3	*	*	*	*
6	GASKET-HYDRAULIC RING.....	3	25AL36	25AL36	25AL36	25AL36
7	CLAMP-LINER.....	3	200PEE455	200PEE455	200PEE455	200PEE455
8	PISTON ROD ASM, Includes item 9...	3	200PEE060	200PEE060	200PEE060	200PEE060
9	NUT, Piston Rod.....	3	50V3	50V3	50V3	50V3
10	LINER.....	3	203PEE456	202PEE456	201PEE456	200PEE456

**PISTONS AND LINERS (TEEG)**  
Well Service – High Pressure Cast Steel – 3”

Ref. No.	Name of Part	Qty.	3.00"	2.75"	2.50"
			Part No.	Part No.	Part No.
1	PISTON BODY ASSEMBLY..... Includes Ref No's 2 & 3	3	228TBA045A	227TBA045A	45R1
2	O-RING.....	3	25AH1	25AH1	***
3	INSERT GROUP, Includes Ref..... Numbers 4 and 5	3	TBA76004	TBA76003	45R8
4	PLATE-RETAINER.....	3	*	*	***
5	RING-RETAINER.....	3	*	*	***
6	GASKET-HYDRAULIC RING.....	3	25AL35	25AL35	25AL35
7	CLAMP-LINER.....	3	1PE217	1PE217	1PE217
8	PISTON ROD ASM, Includes item 9..	3	200PEE060	200PEE060	200PEE060
9	NUT, Piston Rod.....	3	50V3	50V3	50V3
10	LINER.....	3	PE13930	2011248	PE13925

\* Not to be sold separately

\*\*\* 2, 4 and 5 are not applicable for 2.50" size

Order by Part Number and Description. Reference Numbers are shown for your convenience only.

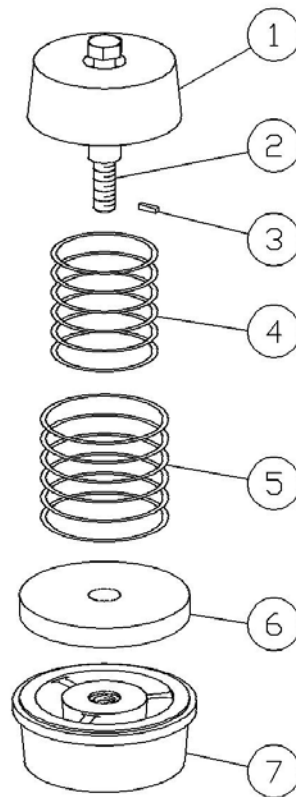

Ref Drawing - 310TEE810

**DELRIN DISC FLUID VALVE  
LOW PRESSURE - CAST ALUMINUM BRONZE CYLINDER - 4"  
SUCTION and DISCHARGE**

Ref. No.	Name of Part	Qty.	Part No.	Part No.	Part No.
			<b>Aluminum Bronze</b>	<b>Stainless Steel</b>	<b>Monel</b>
	FLUID VALVE ASSEMBLY (Includes Items 1 thru 7)	6	200VLH482	201VLH482	202VLH482
1	RETAINER .....	6	2010582	2010583	2010584
2	FASTENER .....	6	2010598	2010598	2010598
3	PLUG-THREAD LOCK .....	6	2010602	2010602	2010602
4	SPRING (Inner).....	6	2010604	2010604	2010604
5	SPRING (Outer).....	6	2010607	2010607	2010607
6	VALVE DISC .....	6	2010611	2010611	2010611
7	VALVE SEAT .....	6	2010623	2010624	2010625

VALVE SEAT PULLER: Use one (1) TEE68700 Valve Puller Group & one (1) 100E6 Puller Head.

Order by Part Number and Description. Reference Numbers are shown for your convenience only.

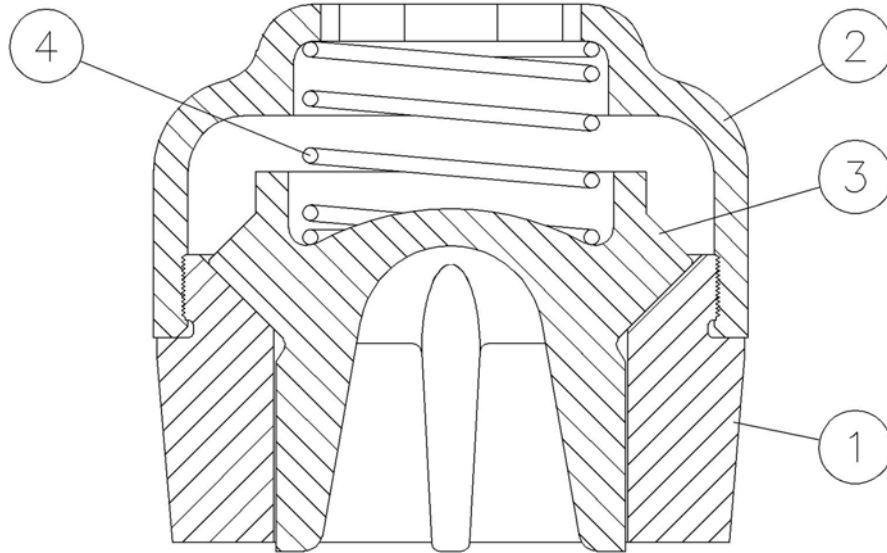

Ref Drawing - 306TEE799

**WING GUIDED FLUID VALVE  
LOW PRESSURE - CAST ALUMINUM BRONZE CYLINDER – 4”  
SUCTION and DISCHARGE  
ALUMINUM BRONZE – WITHOUT INSERT**

Ref. No.	Name of Part	Qty.	Part No.
	FLUID VALVE ASSEMBLY .....	6	208VWH482A
	(Includes Items 1 thru 4)		
1	VALVE SEAT .....	6	200VWH039
2	VALVE CAGE.....	6	200VWH054
3	FLUID VALVE .....	6	3PA206
4	SPRING.....	6	78H29

VALVE SEAT PULLER: Use one (1) TEE68699 Valve Puller Group & one (1) 200PEE219 Puller Head.

**VALVE CAGE WRENCH: 200TEE933**

Order by Part Number and Description. Reference Numbers are shown for your convenience only.

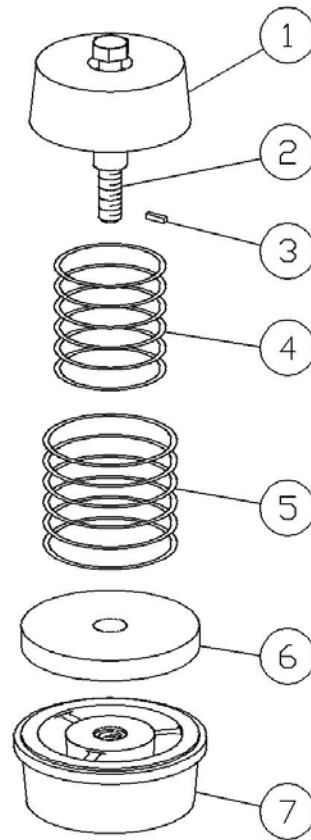

Ref Drawing - 310TEE810

**DELRIN DISC FLUID VALVE  
MEDIUM PRESSURE - CAST ALUMINUM BRONZE CYLINDER - 4"  
SUCTION and DISCHARGE**

Ref. No.	Name of Part	Qty.	Part No.	Part No.	Part No.
			Aluminum Bronze	Stainless Steel	Monel
	FLUID VALVE ASSEMBLY (Includes Items 1 thru 7)	6	200VLF482	201VLF482	202VLF482
1	RETAINER .....	6	2010585	2010586	2010587
2	FASTENER .....	6	2010598	2010598	2010598
3	PLUG-THREAD LOCK .....	6	2010602	2010602	2010602
4	SPRING (Inner).....	6	2010605	2010605	2010605
5	SPRING (Outer).....	6	2010608	2010608	2010608
6	VALVE DISC .....	6	2010612	2010612	2010612
7	VALVE SEAT .....	6	2010629	2010630	2010631

VALVE SEAT PULLER: Use one (1) TEE68700 Valve Puller Group & one (1) 100E5 Puller Head.

Order by Part Number and Description. Reference Numbers are shown for your convenience only.

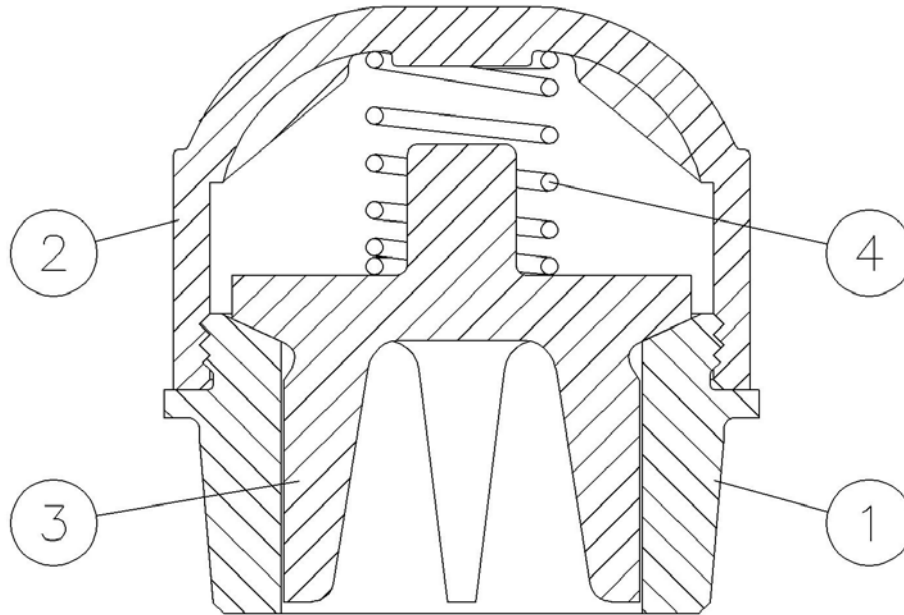

Ref Drawing - 307TEE799

**WING GUIDED FLUID VALVE  
MEDIUM PRESSURE - CAST ALUMINUM BRONZE CYLINDER - 3"  
SUCTION and DISCHARGE  
ALUMINUM BRONZE - WITHOUT INSERT**

Ref. No.	Name of Part	Qty.	Part No.
	FLUID VALVE ASSEMBLY .....	6	208VWF482A
	(Includes Items 1 thru 4)		
1	VALVE SEAT .....	6	200VWF039
2	VALVE CAGE.....	6	200VWF054
3	FLUID VALVE .....	6	PT206
4	SPRING.....	6	78H22

VALVE SEAT PULLER: Use one (1) TEE68699 Valve Puller Group & one (1) 209TAE219 Puller Head.

**VALVE CAGE WRENCH: 16AUX219**

Order by Part Number and Description. Reference Numbers are shown for your convenience only.

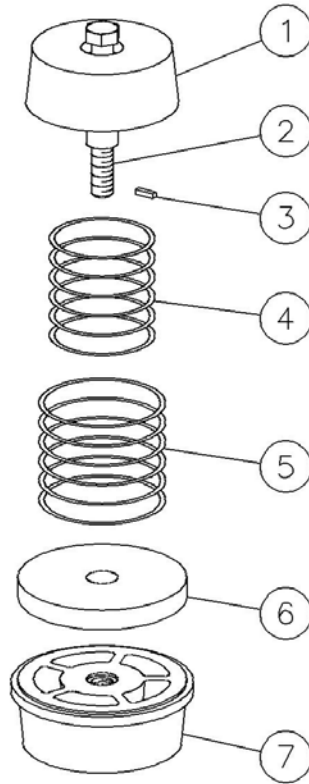

Ref Drawing - 311TEE810

**DELRIN DISC FLUID VALVE  
HIGH PRESSURE - BLOCK STEEL CYLINDER – 2”  
SUCTION VALVE ONLY**

Ref. No.	Name of Part	Qty.	Part No.	Part No.	Part No.
			Aluminum Bronze	Stainless Steel	Monel
	FLUID VALVE ASSEMBLY (Includes Items 1 thru 7)	3	200VHC482	201VHC482	202VHC482
1	RETAINER .....	3	2010591	2010592	2010593
2	FASTENER .....	3	2010600	2010600	2010600
3	PLUG-THREAD LOCK .....	3	2010603	2010603	2010603
4	SPRING (Inner).....	3	2010606	2010606	2010606
5	SPRING (Outer).....	3	2116348	2116348	2116348
6	VALVE DISC .....	3	2010829	2010829	2010829
7	VALVE SEAT .....	3	2010653	2010654	2010655

VALVE SEAT PULLER: Use one (1) TEE68699 Valve Puller Group & one (1) 205TAE219A Puller Head.

Order by Part Number and Description. Reference Numbers are shown for your convenience only.

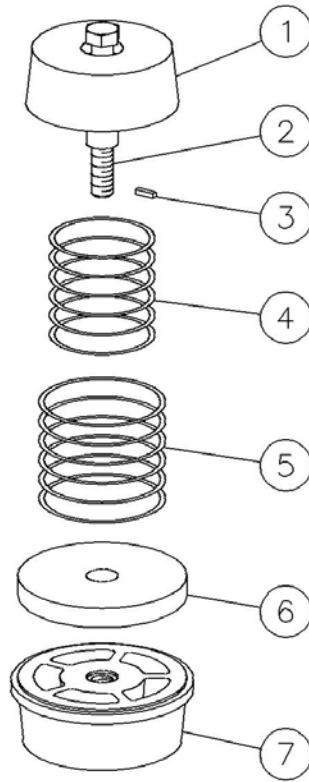

Ref Drawing - 311TEE810

**DELRIN DISC FLUID VALVE  
HIGH PRESSURE - BLOCK STEEL CYLINDER - 2"**

**DISCHARGE VALVE ONLY**

Ref. No.	Name of Part	Qty.	Part No.	Part No.	Part No.
			Aluminum Bronze	Stainless Steel	Monel
	FLUID VALVE ASSEMBLY (Includes Items 1 thru 7)	3	210VHF482	211VHF482	212VHF482
1	RETAINER .....	3	2010588	2010828	2010590
2	FASTENER .....	3	2010599	2010599	2010599
3	PLUG-THREAD LOCK .....	3	2010603	2010603	2010603
4	SPRING (Inner).....	3	2010606	2010606	2010606
5	SPRING (Outer).....	3	2116348	2116348	2116348
6	VALVE DISC .....	3	2010829	2010829	2010829
7	VALVE SEAT .....	3	2109442	2109449	2109445

VALVE SEAT PULLER: Use one (1) TEE68699 Valve Puller Group & one (1) 205TAE219A Puller Head.

Order by Part Number and Description. Reference Numbers are shown for your convenience only.

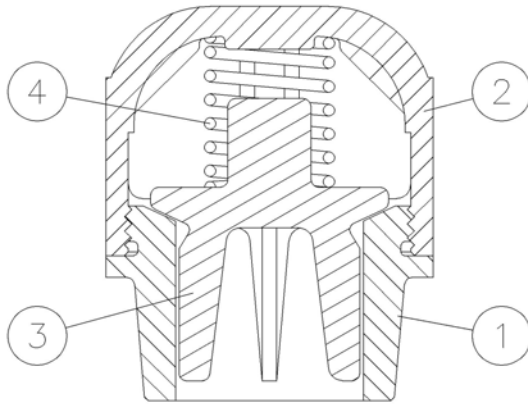

Ref Drawing:  
305TEE799

**SUCTION VALVE**

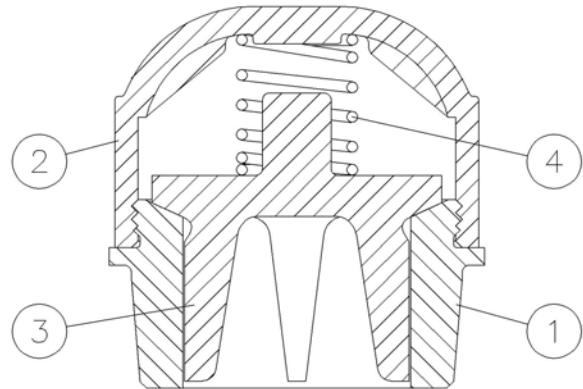

Ref Drawing:  
307TEE799

**DISCHARGE VALVE**

**SUCTION VALVE**  
**WING GUIDED FLUID VALVE**  
**HIGH PRESSURE – BLOCK STEEL CYLINDER – 2”**  
**ALUMINUM BRONZE – WITHOUT INSERT**

Ref No.	Name of Part	Qty.	Part No.
	FLUID VALVE ASSEMBLY .....	3	208VWC482A
	(Includes Items 1 thru 4)		
1	VALVE SEAT .....	3	200VWC039
2	VALVE CAGE.....	3	200VWC054
3	FLUID VALVE .....	3	3PG206
4	SPRING.....	3	78H24

VALVE SEAT PULLER: Use one (1) TEE68699 Valve Puller Group & one (1) 208TAE219 Puller Head.  
VALVE CAGE WRENCH: 200TEE933

**DISCHARGE VALVE**  
**WING GUIDED FLUID VALVE**  
**HIGH PRESSURE – BLOCK STEEL CYLINDER – 2”**  
**ALUMINUM BRONZE – WITHOUT INSERT**

Ref No.	Name of Part	Qty.	Part No.
	FLUID VALVE ASSEMBLY .....	3	208VWF482A
	(Includes Items 1 thru 4)		
1	VALVE SEAT .....	3	200VWF039
2	VALVE CAGE.....	3	200VWF054
3	FLUID VALVE .....	3	PT206
4	SPRING.....	3	78H22

VALVE SEAT PULLER: Use one (1) TEE68699 Valve Puller Group & one (1) 209TAE219 Puller Head.  
VALVE CAGE WRENCH: 200TEE933

Order by Part Number and Description. Reference Numbers are shown for your convenience only.

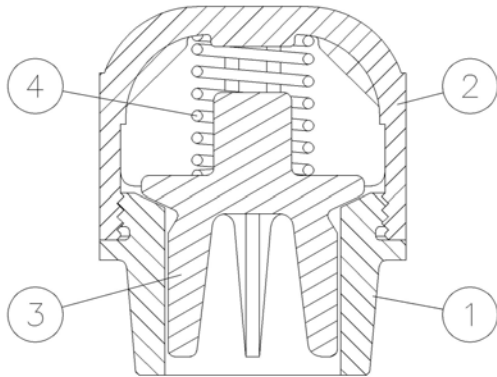

Ref Drawing:  
305TEE799

**SUCTION VALVE**

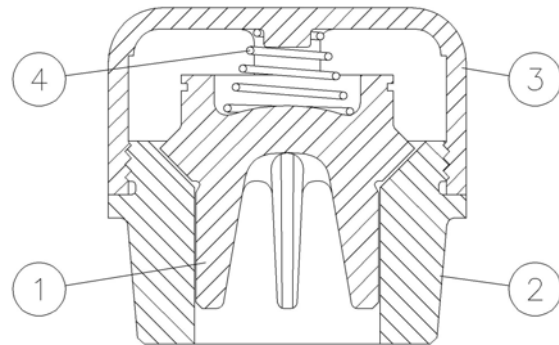

Ref Drawing:  
302TEE799

**DISCHARGE VALVE**

**SUCTION VALVE**  
**WING GUIDED FLUID VALVE**  
**HIGH PRESSURE – BLOCK STEEL CYLINDER – 2”**  
**\*\* HARDENED STEEL – WITHOUT INSERT**

Ref No.	Name of Part	Qty.	Part No.
	FLUID VALVE ASSEMBLY ..... (Includes items 1 thru 4)	3	210VWC482A
1	VALVE SEAT .....	3	201VWC039
2	VALVE CAGE .....	3	201VWC054
3	FLUID VALVE .....	3	6PG206
4	SPRING .....	3	78H22

VALVE SEAT PULLER: Use one (1) TEE68699 Valve Puller Group & one (1) 208TAE219 Puller Head.  
**VALVE CAGE WRENCH: 200TEE933**

\*\* This steel wing guided valve without an insert is for services requiring a discharge pressure over 6500 PSIG.

**DISCHARGE VALVE**  
**WING GUIDED FLUID VALVE**  
**HIGH PRESSURE – BLOCK STEEL CYLINDER – 2”**  
**HARDENED STEEL – WITHOUT INSERT**

Ref No.	Name of Part	Qty.	Part No.
	FLUID VALVE ASSEMBLY ..... (Includes items 1 thru 4)	3	210VWF482A
1	FLUID VALVE .....	3	1PT206
2	VALVE SEAT .....	3	201VWF039
3	VALVE CAGE .....	3	201VWF054
4	SPRING .....	3	78C39

VALVE SEAT PULLER: Use one (1) TEE68699 Valve Puller Group & one (1) 209TAE219 Puller Head.  
**VALVE CAGE WRENCH: 200TEE933**

Order by Part Number and Description. Reference Numbers are shown for your convenience only.

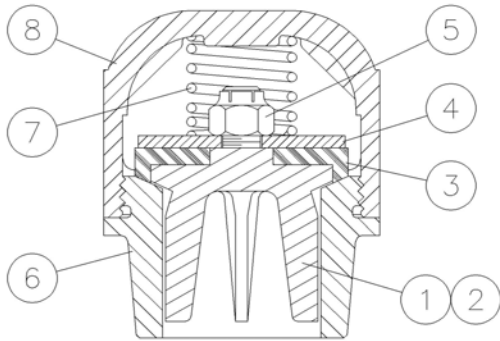

Ref Drawing:  
304TEE799

**SUCTION VALVE**

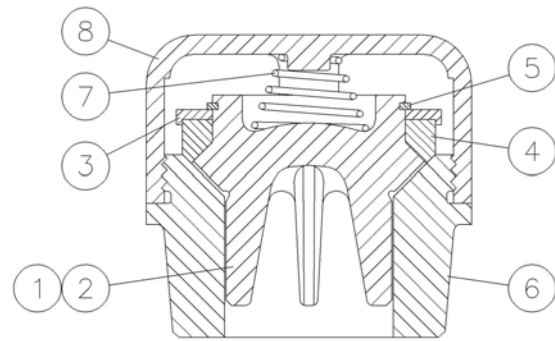

Ref Drawing:  
303TEE799

**DISCHARGE VALVE**

**SUCTION VALVE**  
**WING GUIDED FLUID VALVE**  
**HIGH PRESSURE – BLOCK STEEL CYLINDER – 2”**  
**HARDENED STEEL – WITH A REMOVABLE RUBBER INSERT**

Ref No.	Name of Part	Qty.	Part No.
	FLUID VALVE GROUP, Includes items 1 thru 8 .....	3	211VWC482A
1	FLUID VALVE ASSEMBLY, Includes items 2 thru 5 .....	3	PG206A
2	FLUID VALVE .....	3	PG206
3	INSERT, Rubber .....	3	PG452
4	WASHER, Retainer .....	3	95D166
5	NUT.....	3	50AF3
6	VALVE SEAT .....	3	201VWC039
7	SPRING .....	3	78A148
8	VALVE CAGE .....	3	201VWC054

VALVE SEAT PULLER: Use one (1) TEE68699 Valve Puller Group & one (1) 208TAE219 Puller Head.  
VALVE CAGE WRENCH: 200TEE933

**DISCHARGE VALVE**  
**WING GUIDED FLUID VALVE**  
**HIGH PRESSURE – BLOCK STEEL CYLINDER – 2”**  
**HARDENED STEEL – WITH A REMOVABLE RUBBER INSERT**

Ref No.	Name of Part	Qty.	Part No.
	FLUID VALVE GROUP, Includes items 1 thru 8 .....	3	211VWF482A
1	FLUID VALVE ASSEMBLY, Includes items 2 thru 5 .....	3	1PT206C
2	FLUID VALVE .....	3	1PT206
3	WASHER, Retainer .....	3	PT279
4	INSERT, Rubber .....	3	2PT452
5	RETAINER, Ring .....	3	65W19
6	VALVE SEAT .....	3	201VWF039
7	SPRING .....	3	78C39
8	VALVE CAGE .....	3	201VWF054

VALVE SEAT PULLER: Use one (1) TEE68699 Valve Puller Group & one (1) 209TAE219 Puller Head.  
VALVE CAGE WRENCH: 200TEE933

Order by Part Number and Description. Reference Numbers are shown for your convenience only.

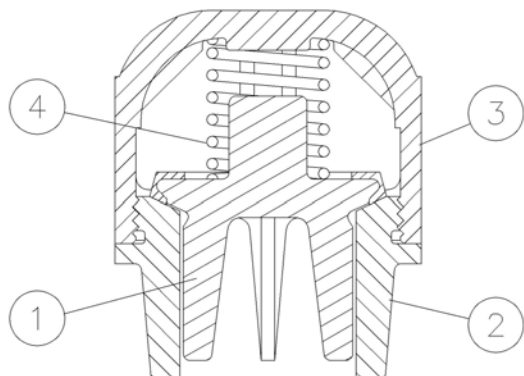

Ref Drawing:  
300TEE799

**SUCTION VALVE**

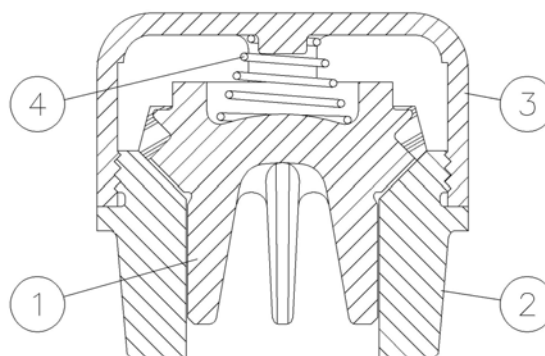

Ref Drawing:  
301TEE799

**DISCHARGE VALVE**

**SUCTION VALVE**

**WING GUIDED FLUID VALVE  
HIGH PRESSURE – BLOCK STEEL CYLINDER – 2”  
HARDENED STEEL – WITH A MOLDED ON INSERT**

Ref No.	Name of Part	Qty.	Part No.
	FLUID VALVE ASSEMBLY .....	3	VWG90867
	(Includes items 1 thru 4)		
1	FLUID VALVE .....	3	215VWG482
2	VALVE SEAT .....	3	201VWC039
3	VALVE CAGE .....	3	201VWC054
4	SPRING .....	3	78H22

VALVE SEAT PULLER: Use one (1) TEE68699 Valve Puller Group & one (1) 208TAE219 Puller Head.

**VALVE CAGE WRENCH: 200TEE933**

**DISCHARGE VALVE**

**WING GUIDED FLUID VALVE  
HIGH PRESSURE – BLOCK STEEL CYLINDER – 2”  
HARDENED STEEL – WITH A MOLDED ON INSERT**

Ref No.	Name of Part	Qty.	Part No.
	FLUID VALVE ASSEMBLY .....	3	VWG90869
	(Includes items 1 thru 4)		
1	FLUID VALVE .....	3	213VWG482
2	VALVE SEAT .....	3	201VWF039
3	VALVE CAGE .....	3	201VWF054
4	SPRING .....	3	78C39

VALVE SEAT PULLER: Use one (1) TEE68699 Valve Puller Group & one (1) 209TAE219 Puller Head.

**VALVE CAGE WRENCH: 200TEE933**

Order by Part Number and Description. Reference Numbers are shown for your convenience only.

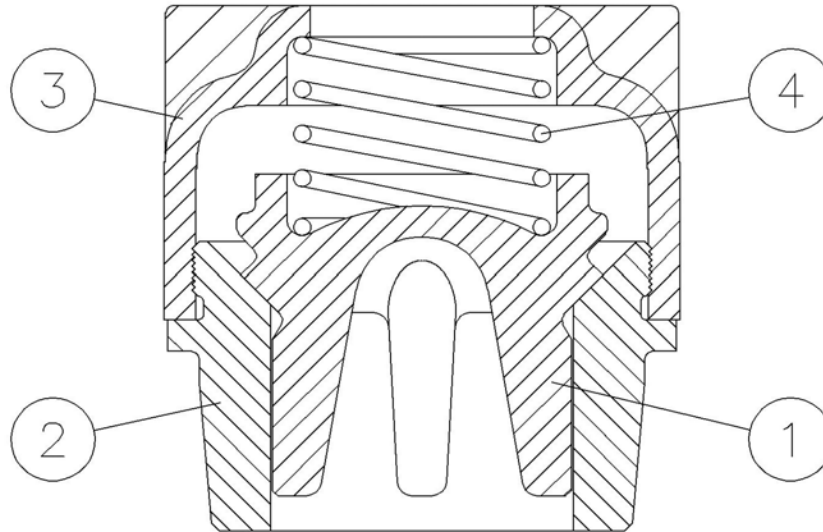

Ref Drawing - 310TEE799

**SUCTION AND DISCHARGE**

**WING GUIDED FLUID VALVE  
HIGH PRESSURE – BLOCK STEEL CYLINDER – 4”  
CAST STEEL – WITHOUT INSERT**

Ref. No.	Name of Part	Qty.	Part No.
	FLUID VALVE ASSEMBLY..... (Includes Items 1 thru 4)	6	TGE90021
1	FLUID VALVE .....	6	202TEE482
2	VALVE SEAT .....	6	200PEE039
3	VALVE CAGE .....	6	200PEE054
4	SPRING .....	6	78H26

VALVE SEAT PULLER: Use one (1) TEE73494 Valve Puller Group & one (1) 200PEE219 Puller Head.

**VALVE CAGE WRENCH: 200TEE933**

Order by Part Number and Description. Reference Numbers are shown for your convenience only.

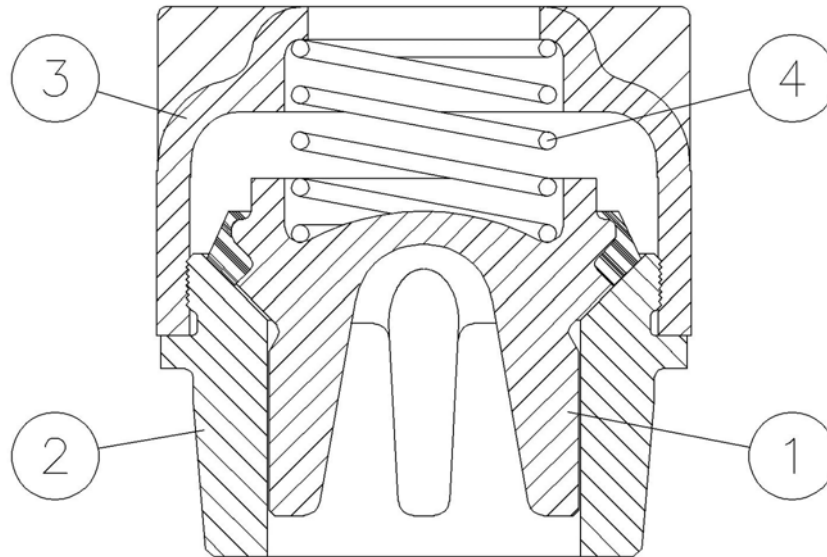

Ref Drawing - 308TEE799

**SUCTION AND DISCHARGE**

**WING GUIDED FLUID VALVE  
HIGH PRESSURE – BLOCK STEEL CYLINDER – 4”  
CAST STEEL – WITH MOLDED ON INSERT  
(CARBOXYLATED RUBBER INSERT)**

Ref. No.	Name of Part	Qty.	Part No.
	FLUID VALVE ASSEMBLY .....	6	TEE90020
	(Includes Items 1 thru 4)		
1	FLUID VALVE .....	6	203TEE482
2	VALVE SEAT .....	6	200PEE039
3	VALVE CAGE .....	6	200PEE054
4	SPRING .....	6	78H26

VALVE SEAT PULLER: Use one (1) TEE73494 Valve Puller Group & one (1) 200PEE219 Puller Head.

**VALVE CAGE WRENCH: 200TEE933**

Order by Part Number and Description. Reference Numbers are shown for your convenience only.

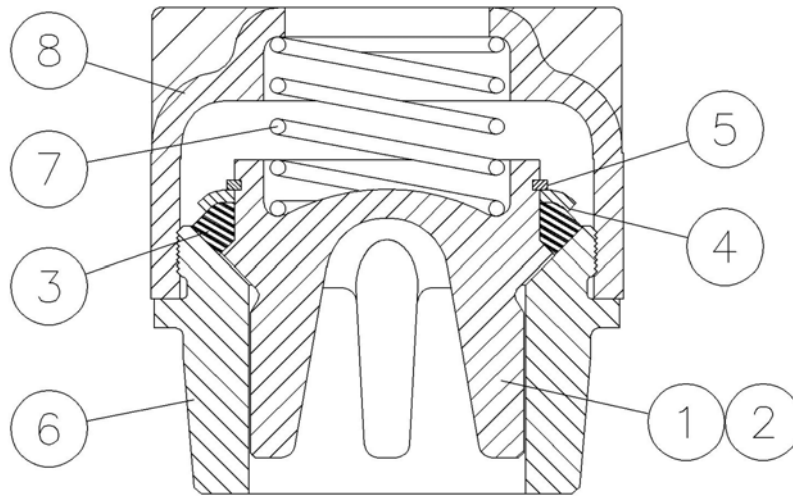

Ref Drawing - 309TEE799

**SUCTION AND DISCHARGE**

**WING GUIDED FLUID VALVE  
HIGH PRESSURE – BLOCK STEEL CYLINDER – 4”  
CAST STEEL – WITH REMOVABLE INSERT  
(URETHANE INSERT)**

Ref. No.	Name of Part	Qty.	Part No.
	FLUID VALVE GROUP, Includes Ref No. 1 thru 8 .....	6	200PEE482B
1	FLUID VALVE ASSEMBLY, Includes Ref No. 2 thru 5 .....	6	200PEE482A
2	FLUID VALVE .....	6	200PEE482
3	VALVE INSERT .....	6	1PA452
4	WASHER .....	6	PA1272
5	RETAINER RING .....	6	74D43
6	VALVE SEAT .....	6	200PEE039
7	SPRING .....	6	78H26
8	VALVE CAGE .....	6	200PEE054

VALVE SEAT PULLER: Use one (1) TEE73494 Valve Puller Group & one (1) 200PEE219 Puller Head.

**VALVE CAGE WRENCH: 200TEE933**

Order by Part Number and Description. Reference Numbers are shown for your convenience only.

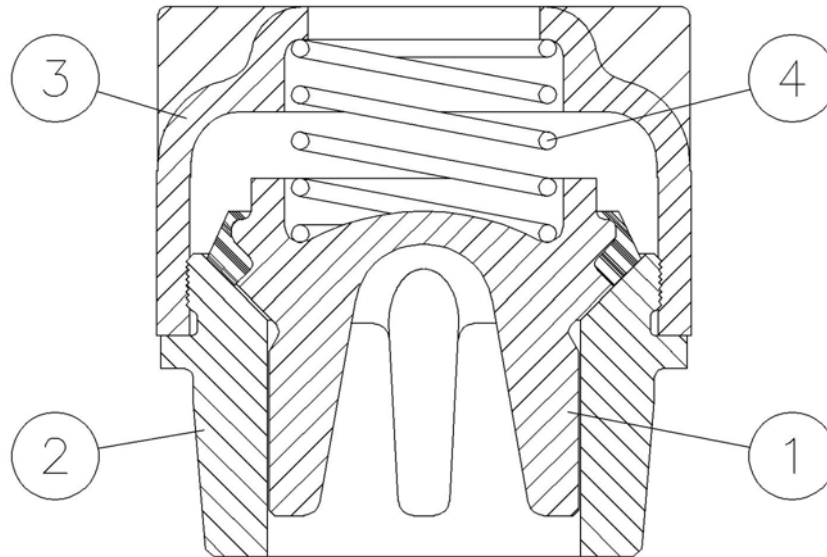

Ref Drawing - 308TEE799

**SUCTION AND DISCHARGE**

**WING GUIDED FLUID VALVE  
HIGH PRESSURE – BLOCK STEEL CYLINDER – 4”  
CAST STEEL – WITH MOLDED ON INSERT  
(POLYURETHANE RUBBER INSERT)**

Ref. No.	Name of Part	Qty.	Part No.
	FLUID VALVE ASSEMBLY .....	6	TEE90019
	(Includes Items 1 thru 4)		
1	FLUID VALVE .....	6	204TEE482
2	VALVE SEAT .....	6	200PEE039
3	VALVE CAGE .....	6	200PEE054
4	SPRING .....	6	78H26

VALVE SEAT PULLER: Use one (1) TEE73494 Valve Puller Group & one (1) 200PEE219 Puller Head.

**VALVE CAGE WRENCH: 200TEE933**

Order by Part Number and Description. Reference Numbers are shown for your convenience only.

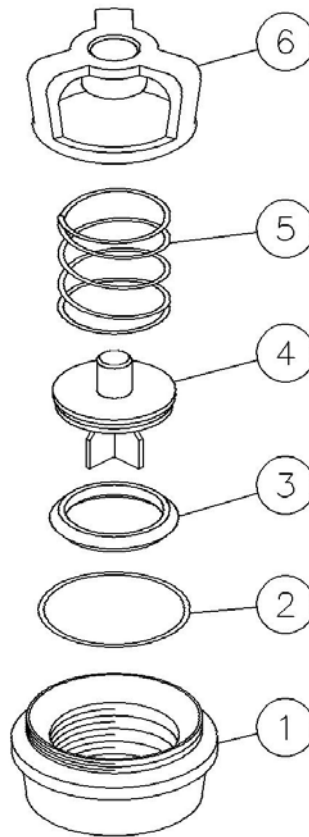

Ref Drawing - 312TEE810

**SUCTION AND DISCHARGE**

**STAINLESS STEEL FLUID VALVE  
HIGH PRESSURE - BLOCK STEEL CYLINDER – 4”  
ABRASION RESISTANT**

Ref. No.	Name of Part	Qty.	Part No.
	FLUID VALVE ASSEMBLY ..... (Includes Items 1 thru 6)	6	209TEE482
1	VALVE SEAT .....	6	2116687
2	O-RING.....	6	2116520
3	VALVE INSERT .....	6	2116521
4	VALVE, Abrasion Resistant.....	6	2116522
5	SPRING .....	6	2116523
6	VALVE CAGE .....	6	2116524

VALVE SEAT PULLER: Use one (1) TEE73494 Valve Puller Group & one (1) 200PEE219 Puller Head.

**VALVE CAGE WRENCH: 200TEE933**

Order by Part Number and Description. Reference Numbers are shown for your convenience only.

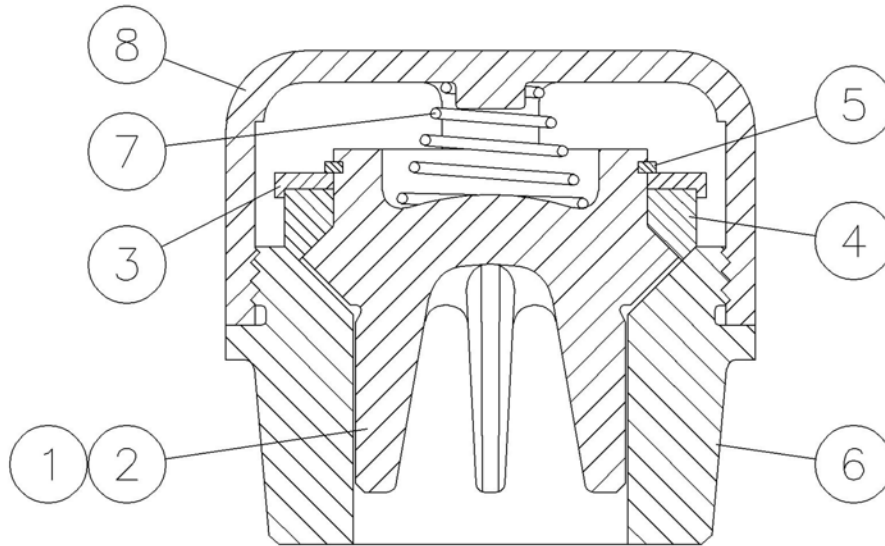

Ref Drawing - 303TEE799

**SUCTION and DISCHARGE VALVE**

**WING GUIDED FLUID VALVE  
HIGH PRESSURE – BLOCK STEEL CYLINDER – 3”  
HARDENED STEEL – WITH A REMOVABLE RUBBER INSERT**

Ref No.	Name of Part	Qty.	Part No.
	FLUID VALVE GROUP, Includes items 1 thru 8 .....	6	211VWF482A
1	FLUID VALVE ASSEMBLY, Includes items 2 thru 5 .....	6	1PT206C
2	FLUID VALVE.....	6	1PT206
3	WASHER, Retainer .....	6	PT279
4	INSERT, Rubber.....	6	2PT452
5	RETAINER, Ring .....	6	65W19
6	VALVE SEAT.....	6	201VWF039
7	SPRING .....	6	78C39
8	VALVE CAGE .....	6	201VWF054

VALVE SEAT PULLER: Use one (1) TEE68699 Valve Puller Group & one (1) 209TAE219 Puller Head.

**VALVE CAGE WRENCH: 200TEE933**

Order by Part Number and Description. Reference Numbers are shown for your convenience only.

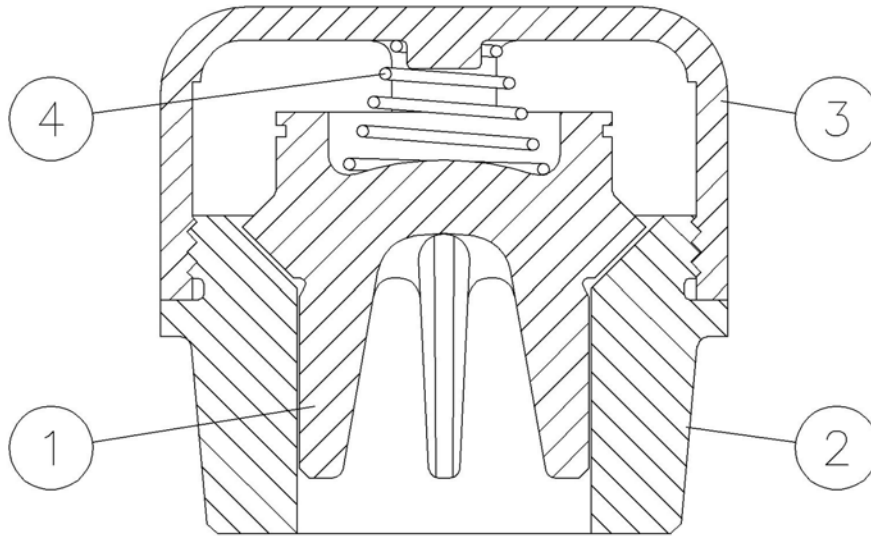

Ref Drawing - 302TEE799

**SUCTION and DISCHARGE VALVE**

**WING GUIDED FLUID VALVE  
HIGH PRESSURE – CAST STEEL CYLINDER – 3”  
HARDENED STEEL – WITHOUT INSERT**

Ref No.	Name of Part	Qty.	Part No.
	FLUID VALVE ASSEMBLY .....	6	210VWF482A
	(Includes items 1 thru 4)		
1	FLUID VALVE .....	6	1PT206
2	VALVE SEAT .....	6	201VWF039
3	VALVE CAGE .....	6	201VWF054
4	SPRING .....	6	78C39

VALVE SEAT PULLER: Use one (1) TEE68699 Valve Puller Group & one (1) 209TAE219 Puller Head.

**VALVE CAGE WRENCH: 200TEE933**

Order by Part Number and Description. Reference Numbers are shown for your convenience only.

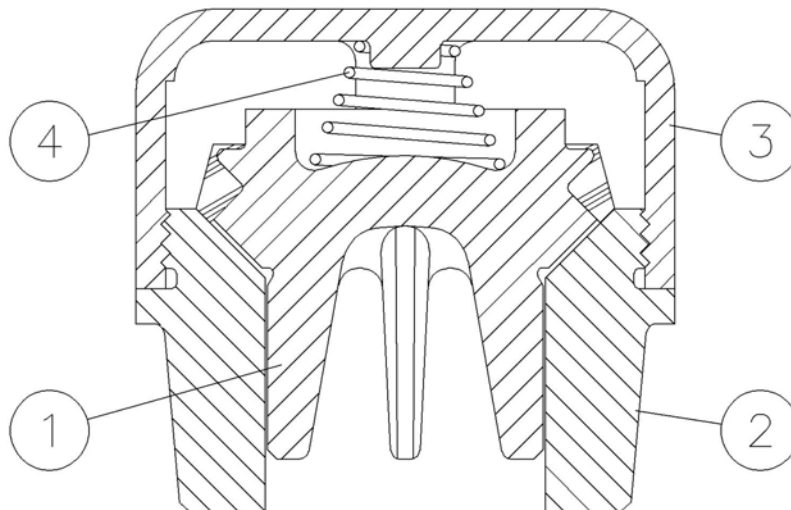

Ref Drawing - 301TEE799

**SUCTION and DISCHARGE VALVE**

**WING GUIDED FLUID VALVE  
HIGH PRESSURE – CAST STEEL CYLINDER – 3”  
HARDENED STEEL – WITH A MOLDED ON INSERT**

<b>Ref No.</b>	<b>Name of Part</b>	<b>Qty.</b>	<b>Part No.</b>
	FLUID VALVE ASSEMBLY .....	6	VWG90869
	(Includes items 1 thru 4)		
1	FLUID VALVE .....	6	213VWG482
2	VALVE SEAT .....	6	201VWF039
3	VALVE CAGE .....	6	201VWF054
4	SPRING .....	6	78C39

VALVE SEAT PULLER: Use one (1) TEE68699 Valve Puller Group & one (1) 209TAE219 Puller Head.

**VALVE CAGE WRENCH: 200TEE933**

Order by Part Number and Description. Reference Numbers are shown for your convenience only.

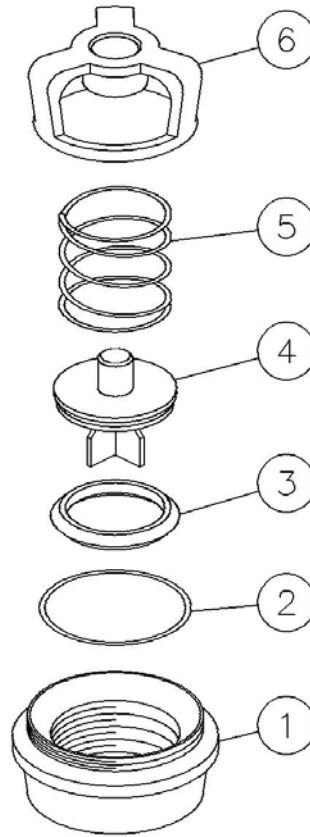

Ref Drawing - 312TEE810

**SUCTION AND DISCHARGE**

**STAINLESS STEEL FLUID VALVE  
HIGH PRESSURE - CAST STEEL CYLINDER – 3”  
ABRASION RESISTANT**

Ref. No.	Name of Part	Qty.	Part No.
	FLUID VALVE ASSEMBLY ..... (Includes Items 1 thru 6)	6	208TEE482
1	VALVE SEAT .....	6	2116561
2	O-RING.....	6	2116284
3	VALVE INSERT .....	6	2116283
4	VALVE, Abrasion Resistant.....	6	2116347
5	SPRING .....	6	2116348
6	VALVE CAGE .....	6	2116282

VALVE SEAT PULLER: Use one (1) TEE68699 Valve Puller Group & one (1) 209TAE219 Puller Head.

**VALVE CAGE WRENCH: 200TEE933**

Order by Part Number and Description. Reference Numbers are shown for your convenience only.

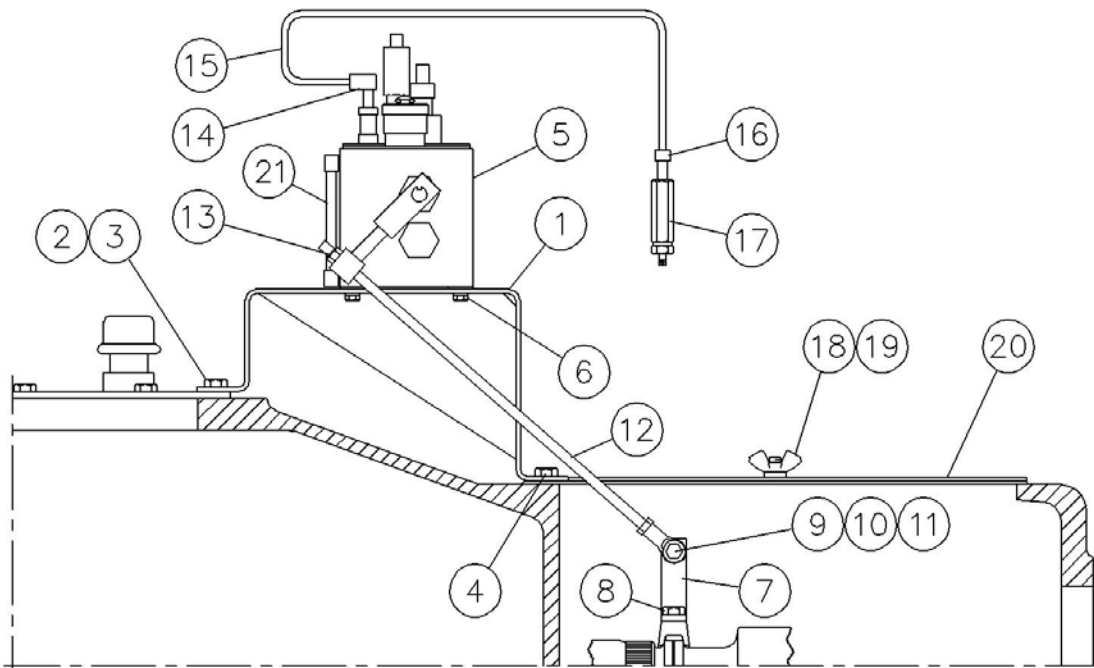

Ref. Drawing - 315TEE810

### LUBRICATOR GROUP (Optional Equipment)

Ref. No.	Description	Qty.	Part No.
	LUBRICATOR GROUP Includes the Following Items.	1	TEE90984
1	BRACKET, Lubricator .....	1	200TEE403
2	SCREW, Bracket to Frame .....	2	655EE040
3	WASHER.....	2	95A5
4	SCREW, Bracket to Frame (Cradle Area).....	2	75LM51
5	LUBRICATOR, (Ratchet Type) .....	1	40G99
6	SCREW, Lubricator to Bracket.....	4	75LM50
7	BRACKET, Lubricator Drive .....	1	200PEE017
8	SCREW, Plunger Coupling .....	2	655EE18Z
9	END, Control Rod.....	1	BM11210A
10	SCREW, Rod End to Drive Bracket .....	1	655ED060
11	WASHER.....	2	95A3
12	CONTROL ROD, Lubricator.....	1	2005879
13	LOCKNUT, Control Rod.....	1	50B3
14	CONNECTOR, Tube - 90 Degree.....	3	86A25
15	TUBING, Lubricator to Stuffing boxes (Length Required for 1 Pump).....	20 Ft.	85E4A
16	CONNECTOR, Tube - Straight .....	3	86A1
17	CHECK VALVE .....	3	90AR373
18	STUD, Cradle Cover .....	2	79A466
19	WINGNUT, Cradle Cover .....	2	50H1
20	INSPECTION PLATE, Cradle Cover.....	1	202TEE052
21	SIGHT GLASS, (Included with Lubricator).....	1	40P15

# PISTON ROD WASH PIPING (Optional Equipment)

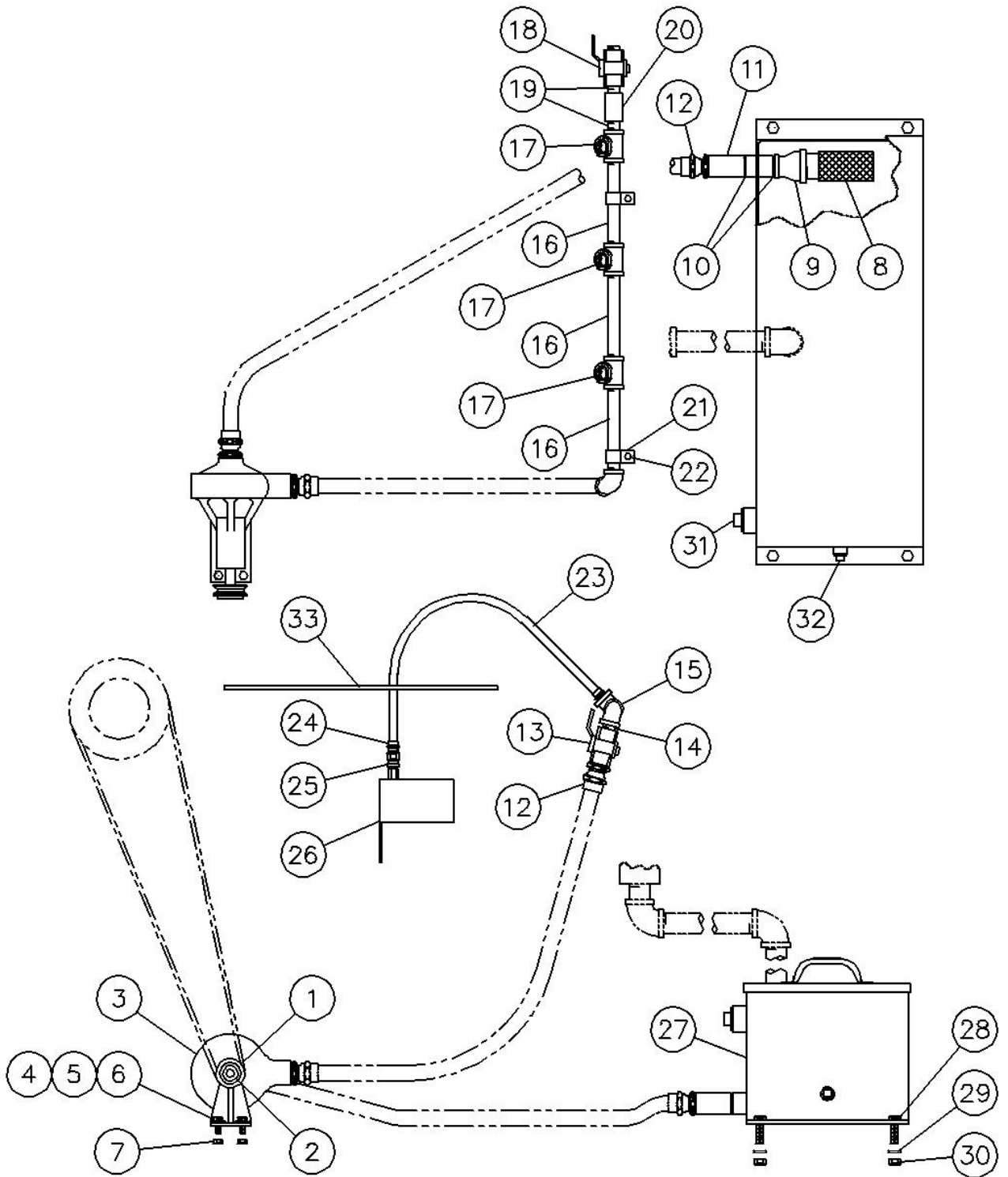

Ref. Drawing - 313TEE810

Order by Part Number and Description. Reference Numbers are shown for your convenience only.

### PISTON ROD WASH PIPING (Optional Equipment)

Ref. No.	Description	Qty.	Part No.
1	SHEAVE, Driven .....	1	73K1A30
2	BUSHING, Sheave.....	1	22E16B
3	CENTRIFUGAL PUMP.....	1	CA122
4	SCREW, Pump to Skid.....	4	655ED040
5	LOCK WASHER.....	4	95B3
6	WASHER.....	4	95A3
7	NUT .....	4	50B3
8	OIL SCREEN.....	1	3WAJ511
9	PIPE REDUCER .....	1	64N7
10	PIPE NIPPLE .....	2	63H1
11	PIPE COUPLING .....	1	64AB4
12	ADAPTOR .....	2	29Q9
13	VALVE, Regulator .....	1	90AR299
14	PIPE NIPPLE .....	1	63H25
15	PIPE ELBOW, 90 Deg.....	1	64S5
16	PIPE NIPPLE .....	3	63G15
17	PIPE TEE .....	3	64P39
18	VALVE, Shut-Off .....	1	90A35
19	PIPE NIPPLE .....	2	63G1
20	PIPE COUPLING .....	1	64AB3
21	CLAMP, Pipe.....	2	98H4
22	SCREW, Clamp to Frame .....	2	655EC020
23	HYDRAULIC HOSE ASSEMBLY .....	3	29R32
24	HOSE ADAPTOR.....	3	29Q7
25	PIPE BUSHING.....	3	64E2
26	BAFFLE.....	3	200TEE840
27	TANK ASSEMBLY, Recovery (Includes the Next Item).....	1	PA252A
	TANK COVER .....	1	PA253
28	SCREW, Tank to Skid .....	4	655EE070
29	LOCK WASHER.....	4	95B5
30	NUT .....	4	50B5
31	PLUG.....	1	64A6
32	PLUG.....	1	64AA7
33	INSPECTION PLATE (Slotted Cradle Cover).....	1	304TEE052

**The Following Will Be Furnished By the Customer: .....**

SHEAVE, Auxiliary Drive.....	1
BELT, Single .....	1
HYDRAULIC HOSE ASSEMBLY (1" with 1" fittings) .....	1
HYDRAULIC HOSE ASSEMBLY (1" with 1" fittings) .....	1
DRAIN, Return .....	1

Order by Part Number and Description. Reference Numbers are shown for your convenience only.

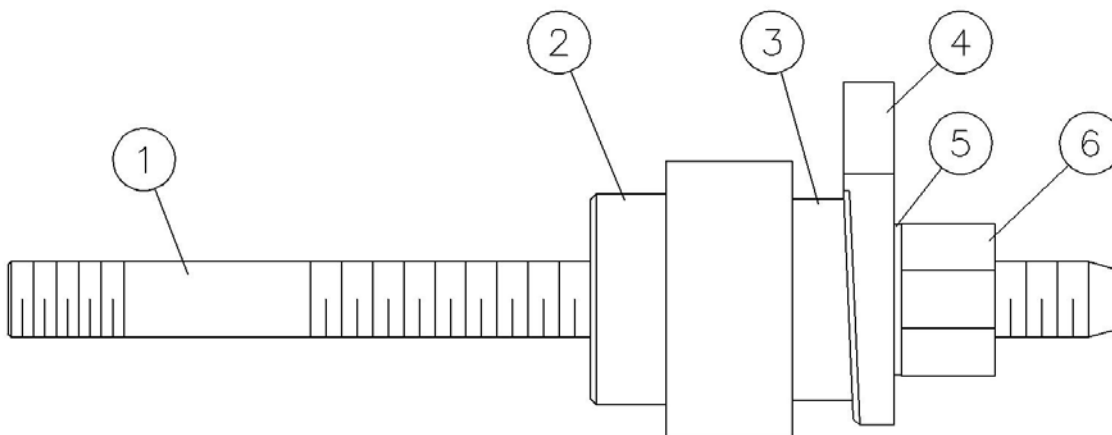

Ref. Drawing - 314TEE810

Ref. No.	Name of Part	Qty.	Part No.	Part No.	Part No.
	VALVE SEAT PULLER GROUP .....	1	TEE68699	TEE68700	TEE73494
	(Includes Items 1 thru 6)				
1	ROD .....	1	200TAE193	200TEE193	200TAE193
2	PULLER PLATE .....	1	200TEE340	200TEE340	202TEE340
3	WASHER .....	1	200TAE244	200TAE244	200TAE244
4	WEDGE .....	1	200TAE091	200TAE091	200TAE091
5	WASHER .....	1	95U14	95U14	95U14
6	NUT.....	1	200TAE086	200TAE086	200TAE086
*	INSTRUCTION TAG	1	201TAE304	201TAE304	201TAE304

\* Not Shown on Illustration

## CUSTOMER REPAIR INFORMATION

### NOTE:

1. TEE Pump with a Serial Number 917132 and Later are equipped with the Two Piece Crosshead / extension rod, as shown on page 6.

Pumps with Serial Numbers previous to 917132 have a One Piece Crosshead / Extension Rod.

For pumps with the earlier Serial Numbers, the 300TEE6005 conversion kit must be used when a repair crosshead is required.

The 300TEE6005 conversion kit includes:

- (1) 300TEE005 CROSSHEAD
- (1) 300TEE839 EXTENSION ROD
- (1) 200TAE840 BAFFLE

2. The PE840 Extension Rod Baffle is required for pumps that do not have the Two Piece Crosshead / Extension Rod construction.
3. Oversized Crossheads are available for pumps with Serial Numbers 917132 and later. (301TEE005)

An Oversized Crosshead Conversion Kit is available for pumps that are equipped with One Piece Crosshead / Extension Rod. (301TEE6005)

The 301TEE6005 conversion kit includes:

- (1) 301TEE005 CROSSHEAD
- (1) 300TEE839 EXTENSION ROD
- (1) 200TAE840 BAFFLE

4. Available Cradle Covers:
  - a. 201TEE052 – Standard
  - b. 202TEE052 – Used with Lubricator Option
  - c. 204TEE052 – Plexiglas (See Through)
  - d. 303TEE052 – Ventilated
  - e. 304TEE052 – Used with Rod Wash Option

5. MODEL	CYLINDER SIZE x STROKE
TEEA	4 x 5
TEEB	3 x 5
TEEC	2 x 5
TEED	4 x 5
TEEE	4 x 5
TEEF	3 x 5
TEEG	3 x 5



## GARDNER DENVER PUMP UNIT RECORD

The following unit identification plate is provided as a convenience to you, our valued Gardner Denver customer. Please take the time to copy all the information from the actual nameplate on your unit. The model number, date manufactured and serial number will be required when contacting the company or your distributor for information or replacement parts.

DANGER-READ INSTRUCTION MANUAL BEFORE MOVING OR OPERATING UNIT						
MODEL	<input style="width: 90%;" type="text"/>	DATE MFG	<input style="width: 90%;" type="text"/>	SERIAL NO.	<input style="width: 95%;" type="text"/>	
ID NO.	<input style="width: 90%;" type="text"/>	MAX TEMP	<input style="width: 90%;" type="text"/>	C/CASE OIL CAP. GAL	<input style="width: 95%;" type="text"/>	
SERVICE	RATED MAX INPUT BHP	RATED MAX INPUT RPM	RATED MAX PUMP RPM	DISCHARGE MAX PSI W.P. OF FLUID CYL.	SUCTION MAX PSI W.P. OF FLUID CYL.	MAX INPUT RPM AT MAX PRESSURE
CONTINUOUS	<input style="width: 90%;" type="text"/>	<input style="width: 90%;" type="text"/>	<input style="width: 90%;" type="text"/>	<input style="width: 90%;" type="text"/>	<input style="width: 90%;" type="text"/>	<input style="width: 90%;" type="text"/>
INTERMITTENT	<input style="width: 90%;" type="text"/>	<input style="width: 90%;" type="text"/>	<input style="width: 90%;" type="text"/>	<input style="width: 90%;" type="text"/>	<input style="width: 90%;" type="text"/>	<input style="width: 90%;" type="text"/>
DISPLACEMENT & PRESSURE AT RATED RPM, SEE O-M MANUAL FOR ADDITIONAL SPECIFICATIONS						
SIZE	<input style="width: 90%;" type="text"/>	<input style="width: 90%;" type="text"/>	<input style="width: 90%;" type="text"/>	<input style="width: 90%;" type="text"/>	<input style="width: 90%;" type="text"/>	<input style="width: 90%;" type="text"/>
GPM	<input style="width: 90%;" type="text"/>	<input style="width: 90%;" type="text"/>	<input style="width: 90%;" type="text"/>	<input style="width: 90%;" type="text"/>	<input style="width: 90%;" type="text"/>	<input style="width: 90%;" type="text"/>
PSI	<input style="width: 90%;" type="text"/>	<input style="width: 90%;" type="text"/>	<input style="width: 90%;" type="text"/>	<input style="width: 90%;" type="text"/>	<input style="width: 90%;" type="text"/>	<input style="width: 90%;" type="text"/>
INTERMITTENT DUTY MAXIMUM PRESSURE, SEE O-M MANUAL FOR ADDITIONAL SPECIFICATIONS						
PSI	<input style="width: 90%;" type="text"/>	<input style="width: 90%;" type="text"/>	<input style="width: 90%;" type="text"/>	<input style="width: 90%;" type="text"/>	<input style="width: 90%;" type="text"/>	<input style="width: 90%;" type="text"/>
<b>Gardner Denver</b>			PURCHASER ID NO.		<input style="width: 95%;" type="text"/>	
2000PA496	Gardner Denver, Inc. Quincy, Illinois					MADE IN USA
GIVE MODEL, ID NO. AND SERIAL NO. WHEN ORDERING REPAIR PARTS OR SERVICE						

Ref. Drawing – 2000PA496

# **Gardner Denver**

## 北京

信德迈科技(北京)有限公司CNMEC Technology  
北京朝阳区胜古中路2号金基业大厦201室  
邮编：100029  
电话：010-8428 2935 13910962635  
传真：010-8428 8762  
主页：[//www.cnmec.biz](http://www.cnmec.biz)  
电子邮件：[sales@cnmec.biz](mailto:sales@cnmec.biz)

## 西安

西安嘉岳自动化技术有限公司Garye Automation  
地址：西安经开区凤城二路天地时代广场B座23层22312室  
邮编：710016  
电话：029 - 8610 8648 15319759129  
传真：029 - 8610 6806  
主页：<http://www.garye.cn>  
电子邮件：[sales@garye.cn](mailto:sales@garye.cn)

Specifications subject to change without notice.

Copyright © 2008 Gardner Denver, Inc. DJC Litho in U.S.A.



For additional information contact your local distributor or

Gardner Denver - Fluid Transfer Division,  
1800 Gardner Expressway, Quincy, Illinois 62301  
Customer Service Department Telephone:  
(800) 682-9868 FAX: (217) 223-1581

For Domestic parts information Contact:  
Gardner Denver – Fluid Transfer Division,  
2200 South Prospect, Oklahoma City, OK. 73129  
Telephone: (405) 677-5736 FAX: (405) 677-5807